

REV.  
C

SAE AS21438

RATIONALE

AS21438 REV C IS A LIMITED SCOPE CHANGE ADDING GRADE B FOR ZINC NICKEL PLATING.

NOTICE

UNDER DEPARTMENT OF DEFENSE POLICIES AND PROCEDURES, ANY QUALIFICATION REQUIREMENTS AND ASSOCIATED QUALIFIED PRODUCTS LISTS ARE MANDATORY FOR DOD CONTRACTS. ANY REQUIREMENT RELATING TO QUALIFIED PRODUCTS LISTS (QPL'S) HAS NOT BEEN ADOPTED BY SAE AND IS NOT PART OF THIS TECHNICAL REPORT.

THE COMPLETE REQUIREMENTS FOR PROCURING THE PRODUCT DESCRIBED HEREIN SHALL CONSIST OF THIS DOCUMENT AND THE LATEST ISSUE OF SAE AS39901.

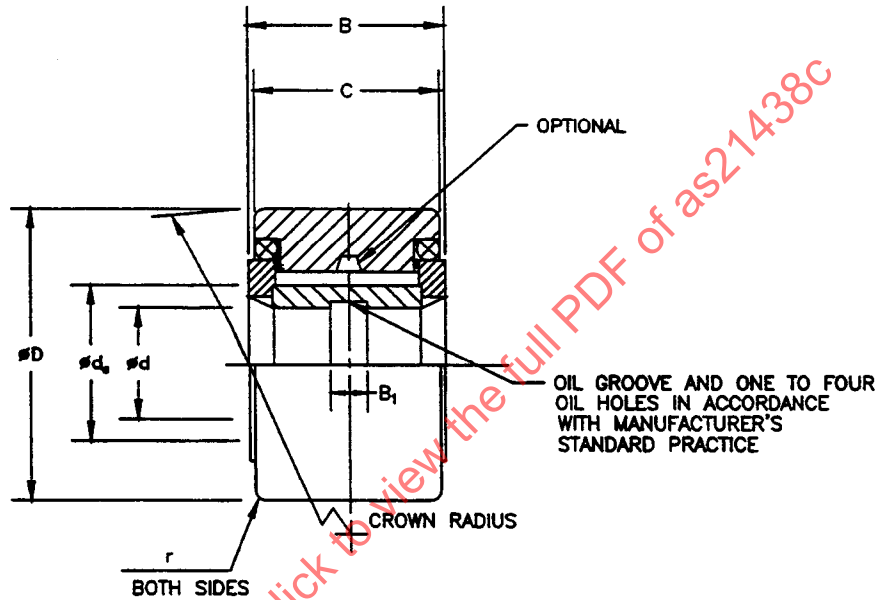
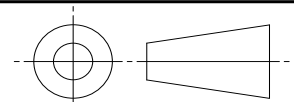

FIGURE 1

SAENORM.COM : Click to view the full PDF of as21438C

SAE values your input. To provide feedback on this Technical Report, please visit <http://www.sae.org/technical/standards/AS21438C>

THIRD ANGLE PROJECTION



CUSTODIAN: ACBG

PROCUREMENT SPECIFICATION: NONE

**SAE Aerospace**  
An SAE International Group

**AEROSPACE STANDARD**

BEARING, ROLLER, NEEDLE, SINGLE ROW, HEAVY DUTY, TRACK ROLLER, SEALED, TYPE V ANTIFRICTION, INCH

**SAE AS21438**  
SUPERSEDES AS24465  
SHEET 1 OF 4

REV.  
C

SAE Technical Standards Board Rules provide that: "This report is published by SAE to advance the state of technical and engineering sciences. The use of this report is entirely voluntary, and its applicability and suitability for any particular use, including any patent infringement arising therefrom, is the sole responsibility of the user."

SAE reviews each technical report at least every five years at which time it may be reaffirmed, revised, stabilized or cancelled. SAE invites your written comments and suggestions.

ISSUED 1998-07 REVISED 2013-01

TABLE 1 - DIMENSIONS

Dash No.	—d Bore	—D Outer Ring Outside Diameter	C Outer Ring Width	B Overall Width	—d <sub>c</sub> Clamping Diameter Min	r Rad Min 1/	B <sub>1</sub> Lubrication Groove Width	Crown Radius Ref.	Total Capacity Clearance Max.	Capacity As a Track Roller Lb.	Track Capacity 40 HRC lb.	Limit Load Rating Lb.	Mass (Approx) lbs.
-103	.1900	.7500	.280	0.312	0.438	0.022	0.094	10.000	0.0018	900	290	1200	0.03
-104	.2500	.8750	.345	0.375	0.516	0.022	0.125	10.000	0.0018	1430	575	1910	0.05
-106	.3750	1.0625	.455	0.500	0.672	0.022	0.188	10.000	0.0018	2700	1000	3600	0.10
-108	.5000	1.3125	.580	0.625	0.844	0.032	0.188	12.500	0.0018	4300	1785	5780	0.18
-110	.6250	1.5000	.705	0.750	0.953	0.032	0.250	17.500	0.0018	6400	2600	8500	0.28
-112	.7500	1.7500	.950	1.000	1.109	0.032	0.250	25.000	0.0018	18700	4050	14200	0.52
-114	.8750	2.0000	1.075	1.125	1.219	0.032	0.250	27.500	0.0018	14400	5350	19300	0.75
-120	1.2500	2.5000	1.200	1.250	1.625	0.032	0.375	30.000	0.0018	18900	7100	25300	1.16
-124	1.5000	3.0000	1.440	1.500	2.000	0.032	0.375	60.000	0.0018	28400	18900	37900	2.36
-128	1.7500	3.4375	1.440	1.500	2.281	0.032	0.375	60.000	0.0018	33000	12400	44100	2.71
-132	2.0000	3.8750	1.440	1.500	2.562	0.032	0.375	60.000	0.0018	36700	14000	48900	3.42
-136	2.2500	4.3125	1.440	1.500	2.859	0.032	0.375	60.000	0.0018	41200	15600	55000	4.23
-140	2.2000	4.7500	1.440	1.500	3.109	0.032	0.375	60.000	0.0020	44900	17200	59900	5.14
-144	2.7500	5.0000	1.440	1.500	3.344	0.032	0.375	60.000	0.0020	46800	18100	64800	5.49

TABLE 2 - TOLERANCE VALUES

Dimensions in inches

—d Basic Bore		Allowable Deviation From d of Single Mean Dia., d <sub>mp</sub>		Allowable Deviation From Overall Width B		Allowable Deviation From Lubrication Groove Width B <sub>1</sub>		—D Basic Outside Dia.		Allowable Deviation From d of Single Dia., D <sub>mp</sub>		Allowable Deviation From Outer Ring Width C	
Over	Incl	High	Low	High	Low	High	Low	Over	Incl	High	Low	High	Low
0.1250	2.7500	0	-0.0007	0	-0.010	0	-0.062	0.6875	5.0000	+0.001	-0.001	0	-0.015

1. MATERIAL:

- a. INNER RING, OUTER RING AND NEEDLES: 52100 STEEL PER AMS6440, AMS6444, AMS6447, OR ASTM A295.
- b. ENDWASHERS: 52100 STEEL PER AMS6440, AMS6444, AMS6447, OR ASTM A295. AISI 1074 STEEL PER ASTM A684.
- c. SEALS AND BACKING RINGS - ACETAL RESIN PER ASTM D6778 POM 111 OR NYLON PER L-P-410, TYPE 6/6, WEAR RESISTANT GRADE, OR POLYESTER ELASTOMER. CONSTRUCTION OPTIONAL.
- d. RETAINING RINGS: BRASS (OPTIONAL)

2. HEAT TREAT:

- a. OUTER RING: HARDEN AND TEMPER TO 58-62 HRC
- b. INNER RING: HARDEN AND TEMPER TO 60-64 HRC OR INDUCTION HARDEN TO 60-64 HRC FOR .015 INCH MINIMUM DEPTH AND 50 HRC AT .030 INCH MINIMUM DEPTH.
- c. NEEDLES: HARDEN AND TEMPER TO 60-64 HRC
- d. ENDWASHERS: HARDEN AND TEMPER TO 51-56 HRC

3. FINISH OR PLATING:

- a. OUTER RING - OUTER RING CHROME PLATED PER AMS-QQ-C-320, CLASS 2. O.D. AND O.D. CORNERS .0004 TO .0010 INCH THICKNESS, FACES MINIMUM .0003 INCH THICKNESS.
- b. INNER RING - ALL EXTERNAL SURFACES BLACK OXIDE PER MIL-DTL-13924.
- c. ENDPLATES - ALL EXPOSED SURFACES ZINC-NICKEL IN ACCORDANCE AMS2417, TYPE 2, GRADE B OR CADMIUM PLATED IN ACCORDANCE WITH AMS-QQ-P-416, TYPE I, CLASS 2, WITH A THICKNESS OF .0003 TO .0006 INCHES. IF ZINC-NICKEL PLATING IS REQUIRED, ADD THE LETTER "E" AFTER THE MS21438 DASH NUMBER. NO CODE DESIGNATES CADMIUM PLATING IS REQUIRED.

4. SURFACE TEXTURE:

RACEWAYS - 16 MICROINCHES MAXIMUM Ra

BORE AND O.D. - 40 MICROINCHES MAXIMUM Ra

NEEDLE O.D. - 8 MICROINCHES MAXIMUM Ra

- 5. LUBRICANT: MIL-PRF-81322 OR MIL-PRF-23827. ALL BEARINGS SHALL BE PREPACKED WITH GREASE CONFORMING TO MIL-PRF-81322 UNLESS OTHERWISE SPECIFIED. IF MIL-PRF-23827 TYPE 1 GREASE IS REQUIRED, ADD THE SUFFIX "G" TO THE MS DASH NUMBER. IF MIL-PRF-23827 TYPE 2 GREASE IS REQUIRED, ADD THE SUFFIX "J" TO THE MS DASH NUMBER.
- 6. MARKING: THE MARKING SHALL CONSIST OF THE MS PART NUMBER AND THE MANUFACTURER'S CAGE CODE MARKED IN ACCORDANCE WITH MIL-STD-130 AND A LOT CONTROL NUMBER IF SPACE IS AVAILABLE.
- 7. PART NUMBER: THE PART NUMBER SHALL CONSIST OF THE MS SPECIFICATION NUMBER FOLLOWED BY A DASH NUMBER TAKEN FROM TABLE 1 AND APPLICABLE SUFFIXES. FINISH SUFFIX TO BE DESIGNATED BEFORE LUBRICANT SUFFIX.  
  
EXAMPLE: MS21438-103EG
- 8. PACKAGING: BEARINGS SHALL BE INDIVIDUALLY PACKAGED TO THE REQUIREMENTS OF MIL-DTL-197. PACKAGE MARKED WITH MANUFACTURER'S NAME OR TRADEMARK, AND DATE OF LUBRICATION BY MONTH AND YEAR AND LOT CONTROL NUMBER.
- 9. DIMENSIONS: ALL DIMENSIONS ARE AFTER PLATING AND ARE IN INCHES.
- 10. LOAD RATING: THE LIMIT LOAD RATING LISTED CAN BE DEFINED AS THE MAXIMUM RADIAL LOAD WHICH CAN BE APPLIED TO A BEARING WITHOUT IMPAIRING THE SUBSEQUENT FUNCTIONING OF THE BEARING. THE ULTIMATE OR STATIC FRACTURE LOAD RATING IS NOT LESS THAN 1.5 TIMES THE LIMIT LOAD RATING. THE LOAD RATING AS A TRACK ROLLER IS THE LOAD THE BEARING WILL CARRY AS A TRACK ROLLER FOR AN L -10 LIFE OF 20 000 REVOLUTIONS.

11. TEMPERATURE:

OPERATING TEMPERATURE RANGE -65 TO 350 °F FOR MIL-PRF-81322 LUBRICATED BEARINGS OPERATING TEMPERATURE RANGE -65 TO 250 °F FOR MIL-PRF-23827 LUBRICATED BEARINGS.

12. REMOVE ALL BURRS AND SHARP EDGES.

 An SAE International Group	<b>AEROSPACE STANDARD</b>	<b>SAE AS21438</b> SHEET 3 OF 4	<b>REV.</b> <b>C</b>
	BEARING, ROLLER, NEEDLE, SINGLE ROW, HEAVY DUTY, TRACK ROLLER, SEALED, TYPE V ANTIFRICTION, INCH		