**Geometrical product specifications
(GPS) — Acceptance and reverification
tests for coordinate measuring machines
(CMM) —**

Part 2:
**CMMs used for measuring linear
dimensions**

*Spécification géométrique des produits (GPS) — Essais de réception et
de vérification périodique des machines à mesurer tridimensionnelles
(MMT) —*

Partie 2: MMT utilisées pour les mesures de dimensions linéaires



PDF disclaimer

This PDF file may contain embedded typefaces. In accordance with Adobe's licensing policy, this file may be printed or viewed but shall not be edited unless the typefaces which are embedded are licensed to and installed on the computer performing the editing. In downloading this file, parties accept therein the responsibility of not infringing Adobe's licensing policy. The ISO Central Secretariat accepts no liability in this area.

Adobe is a trademark of Adobe Systems Incorporated.

Details of the software products used to create this PDF file can be found in the General Info relative to the file; the PDF-creation parameters were optimized for printing. Every care has been taken to ensure that the file is suitable for use by ISO member bodies. In the unlikely event that a problem relating to it is found, please inform the Central Secretariat at the address given below.

STANDARDSISO.COM : Click to view the full PDF of ISO 10360-2:2009



COPYRIGHT PROTECTED DOCUMENT

© ISO 2009

All rights reserved. Unless otherwise specified, no part of this publication may be reproduced or utilized in any form or by any means, electronic or mechanical, including photocopying and microfilm, without permission in writing from either ISO at the address below or ISO's member body in the country of the requester.

ISO copyright office
Case postale 56 • CH-1211 Geneva 20
Tel. + 41 22 749 01 11
Fax + 41 22 749 09 47
E-mail copyright@iso.org
Web www.iso.org

Published in Switzerland

Contents

Page

Foreword	v
Introduction.....	vi
1 Scope	1
2 Normative references	1
3 Terms and definitions	2
4 Symbols	4
5 Environmental and metrological requirements	4
5.1 Environmental conditions	4
5.2 Operating conditions	5
5.3 Length measurement error, E_L	5
5.4 Repeatability range of the length measurement error, R_0	5
5.5 Workpiece loading effects	5
6 Acceptance tests and reverification tests	6
6.1 General	6
6.2 Principle.....	6
6.3 Length measurement error with zero ram axis stylus tip offset, E_0	7
6.3.1 General	7
6.3.2 Measuring equipment	7
6.3.3 Procedure	8
6.3.4 Derivation of test results	9
6.4 Repeatability range of the length measurement error, R_0	9
6.5 Length measurement error with ram axis stylus tip offset of 150 mm, E_{150}	10
6.5.1 Measuring equipment	10
6.5.2 Procedure	10
6.5.3 Derivation of test results	12
6.6 Dual ram CMMs.....	12
6.6.1 Simplex operating mode.....	12
6.6.2 Duplex operating mode.....	12
7 Compliance with specifications	13
7.1 Acceptance test.....	13
7.1.1 Acceptance criteria	13
7.1.2 Data rejection and repeated measurements.....	14
7.2 Reverification test	14
8 Applications	14
8.1 Acceptance test.....	14
8.2 Reverification test	15
8.3 Interim check	15
9 Indication in product documentation and data sheets	15
Annex A (informative) Interim check	16
Annex B (normative) Artefacts that represent a calibrated test length	18
Annex C (informative) Alignment of gauges	23
Annex D (normative) Mathematical adjustments to low CTE artefacts	25
Annex E (informative) Location of the single stylus probing test	27

Annex F (informative) Relation to the GPS matrix model28
Bibliography29

STANDARDSISO.COM : Click to view the full PDF of ISO 10360-2:2009

Foreword

ISO (the International Organization for Standardization) is a worldwide federation of national standards bodies (ISO member bodies). The work of preparing International Standards is normally carried out through ISO technical committees. Each member body interested in a subject for which a technical committee has been established has the right to be represented on that committee. International organizations, governmental and non-governmental, in liaison with ISO, also take part in the work. ISO collaborates closely with the International Electrotechnical Commission (IEC) on all matters of electrotechnical standardization.

International Standards are drafted in accordance with the rules given in the ISO/IEC Directives, Part 2.

The main task of technical committees is to prepare International Standards. Draft International Standards adopted by the technical committees are circulated to the member bodies for voting. Publication as an International Standard requires approval by at least 75 % of the member bodies casting a vote.

Attention is drawn to the possibility that some of the elements of this document may be the subject of patent rights. ISO shall not be held responsible for identifying any or all such patent rights.

ISO 10360-2 was prepared by Technical Committee ISO/TC 213, *Dimensional and geometrical product specifications and verification*.

This third edition cancels and replaces the second edition (ISO 10360-2:2001), which has been technically revised.

ISO 10360 consists of the following parts, under the general title *Geometrical product specifications (GPS) — Acceptance and reverification tests for coordinate measuring machines (CMM)*:

- *Part 1: Vocabulary*
- *Part 2: CMMs used for measuring linear dimensions*
- *Part 3: CMMs with the axis of a rotary table as the fourth axis*
- *Part 4: CMMs used in scanning measuring mode*
- *Part 5: CMMs using single and multiple stylus contacting probing systems*
- *Part 6: Estimation of errors in computing Gaussian associated features*
- *Part 7: CMMs equipped with imaging probing systems*

Introduction

This part of ISO 10360 is a geometrical product specification (GPS) standard and is to be regarded as a general GPS standard (see ISO/TR 14638). It influences link 5 of the chains of standards on size, distance, radius, angle, form, orientation, location, run-out and datums. For more detailed information of the relation of this part of ISO 10360 to other standards and the GPS matrix model, see Annex F.

The tests of this part of ISO 10360 have three technical objectives:

- 1) to test the error of indication of a calibrated test length using a probing system without any ram axis stylus tip offset;
- 2) to test the error of indication of a calibrated test length using a probing system with a specified ram axis stylus tip offset; and
- 3) to test the repeatability of measuring a calibrated test length.

The benefits of these tests are that the measured result has a direct traceability to the unit length, the metre, and that it gives information on how the CMM will perform on similar length measurements.

Clause 3 of this part of ISO 10360 contains definitions that supersede similar definitions in ISO 10360-1:2000.

The revised definitions are required to avoid an ambiguity that would otherwise have been introduced with this issue of ISO 10360-2. Also, definition 3.6 supersedes effectively an identical definition in ISO 10360-1:2000 because the symbols used have been revised and expanded for clarification.

STANDARDSISO.COM : Click to view the full PDF of ISO 10360-2:2009

Geometrical product specifications (GPS) — Acceptance and reverification tests for coordinate measuring machines (CMM) —

Part 2: CMMs used for measuring linear dimensions

1 Scope

This part of ISO 10360 specifies the acceptance tests for verifying the performance of a coordinate measuring machine (CMM) used for measuring linear dimensions as stated by the manufacturer. It also specifies the reverification tests that enable the user to periodically reverify the performance of the CMM.

The acceptance and reverification tests given in this part of ISO 10360 are applicable only to Cartesian CMMs using contacting probing systems of any type operating in the discrete-point probing mode.

This part of ISO 10360 does not explicitly apply to:

- non-Cartesian CMMs; however, parties may apply this part of ISO 10360 to non-Cartesian CMMs by mutual agreement;
- CMMs using optical probing; however, parties may apply this approach to optical CMMs by mutual agreement.

This part of ISO 10360 specifies performance requirements that can be assigned by the manufacturer or the user of a CMM, the manner of execution of the acceptance and reverification tests to demonstrate the stated requirements, rules for proving conformance, and applications for which the acceptance and reverification tests can be used.

2 Normative references

The following referenced documents are indispensable for the application of this document. For dated references, only the edition cited applies. For undated references, the latest edition of the referenced document (including any amendments) applies.

ISO 10360-1:2000, *Geometrical Product Specifications (GPS) — Acceptance and reverification tests for coordinate measuring machines (CMM) — Part 1: Vocabulary*

ISO 14253-1:1998, *Geometrical Product Specifications (GPS) — Inspection by measurement of workpieces and measuring equipment — Part 1: Decision rules for proving conformance or non-conformance with specifications*

ISO 14660-1:1999, *Geometrical Product Specifications (GPS) — Geometrical features — Part 1: General terms and definitions*

ISO/TS 23165:2006, *Geometrical product specifications (GPS) — Guidelines for the evaluation of coordinate measuring machine (CMM) test uncertainty*

ISO/IEC Guide 99, *International vocabulary of metrology — Basic and general concepts and associated terms (VIM)*

3 Terms and definitions

For the purposes of this document, the terms and definitions given in ISO 10360-1, ISO 14253-1, ISO 14660-1, ISO/TS 23165, ISO/IEC Guide 99 and the following apply.

3.1 ram axis stylus tip offset

L
distance (orthogonal to the ram axis) between the stylus tip and a reference point

NOTE 1 The reference point is defined by the manufacturer. If no manufacturer-defined reference point is known, the user chooses a reference point close to the probe system mount.

NOTE 2 The reference point is usually in or near the probe system.

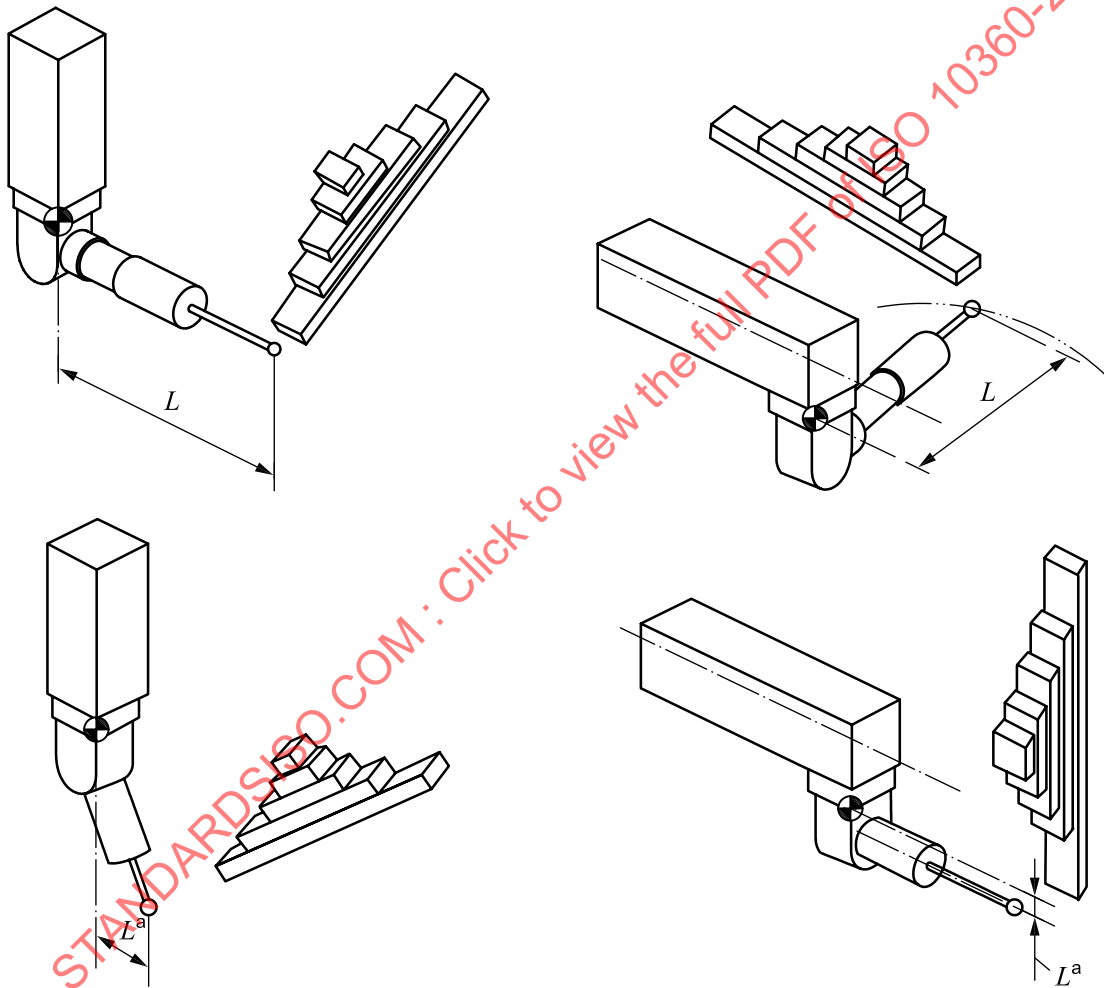

a $L \approx 0$.

Figure 1 — Examples of the ram axis stylus tip offset in the case of an articulated probing system

3.2 coefficient of thermal expansion CTE

α
linear thermal expansion coefficient of a material at 20 °C

3.3**normal CTE material**

material with a CTE between $8 \times 10^{-6}/^{\circ}\text{C}$ and $13 \times 10^{-6}/^{\circ}\text{C}$

3.4**length measurement error**

E_L

error of indication when measuring a calibrated test length using a CMM with a ram axis stylus tip offset of L , using a single probing point (or equivalent) at each end of the calibrated test length

NOTE 1 In this part of ISO 10360, $L = 0$ mm and $L = 150$ mm (default values) are specified.

NOTE 2 See Annex B for the requirements of point sampling strategies.

3.5**repeatability range of the length measurement error**

R_0

range (largest minus smallest) of three repeated length measurement errors measured by a CMM with zero ram axis stylus tip offset

3.6**maximum permissible error of length measurement**

$E_{L, \text{MPE}}$

extreme value of the length measurement error, E_L , permitted by specifications

NOTE 1 In this part of ISO 10360, $L = 0$ mm and $L = 150$ mm (default values) are specified.

NOTE 2 A maximum permissible error (MPE) as opposed to a maximum permissible limit (MPL) specification is used when the test measurements determine errors; hence, testing an MPE specification requires the use of calibrated artefacts.

NOTE 3 The MPE may be expressed using any of the methods shown in Figure 12, Figure 13 and Figure 14 of ISO 10360-1:2000.

3.7**maximum permissible limit of the repeatability range**

$R_{0, \text{MPL}}$

extreme value of the repeatability range of the length measurement error, R_0 , permitted by specifications

NOTE 1 A maximum permissible limit (MPL) as opposed to a maximum permissible error (MPE) specification is used when the test measurements are not errors; hence, testing an MPL specification does not require the use of calibrated artefacts.

NOTE 2 The MPL may be expressed using any of the methods shown in Figure 12, Figure 13 and Figure 14 of ISO 10360-1:2000.

3.8**dual ram CMM**

CMM composed of two independent rams and a method for reporting the coordinate measurements from both rams in a single coordinate system

NOTE 1 The two rams usually share part of their measuring range, but this is not required.

NOTE 2 The method for establishing a single coordinate system may require an alignment procedure.

NOTE 3 A dual ram CMM may report the results of each ram in separate coordinate systems; see **simplex operating mode** (3.9).

**3.9
simplex operating mode**

method of using a dual ram CMM in which the two rams are treated as separate measuring systems

NOTE In the simplex operating mode, the coordinate measurements from the two rams are not reported in a single coordinate system.

**3.10
duplex operating mode**

method of using a dual ram CMM in which the coordinate measurements from the two rams are reported in a single coordinate system

4 Symbols

For the purpose of this document, the symbols in Table 1 apply.

Table 1 — Symbols

Symbol	Meaning
E_L	Length measurement error
R_0	Repeatability range of the length measurement error
$E_{L, MPE}$	Maximum permissible error of length measurement
$R_{0, MPL}$	Maximum permissible limit of the repeatability range

NOTE See Clause 9 with respect to the indications of these symbols in product documentation, drawings, data sheets, etc.

5 Environmental and metrological requirements

5.1 Environmental conditions

Limits for permissible environmental conditions, such as temperature conditions, air humidity and vibration at the site of installation, that influence the measurements shall be specified by:

- the manufacturer, in the case of acceptance tests;
- the user, in the case of reverification tests.

In both cases, the user is free to choose the environmental conditions under which the ISO 10360-2 testing will be performed within the specified limits (as supplied in the data sheet of the manufacturer; see ISO 10360-1, Amendment 1).

The user is responsible for providing the environment enclosing the CMM, as specified by the manufacturer in the data sheet.

If the environment does not meet the specifications, then verification of the maximum permissible errors, $E_{0, MPE}$, $E_{L, MPE}$, and maximum permissible limit, $R_{0, MPL}$, cannot be required.

5.2 Operating conditions

The CMM shall be operated using the procedures given in the manufacturer's operating manual when conducting the tests given in Clause 6.

Specific areas in the manufacturer's manual to be adhered to are, for example:

- a) machine start-up/warm-up cycles;
- b) stylus system configuration;
- c) cleaning procedures for stylus tip;
- d) probing system qualification;
- e) thermal stability of the probing system before calibration;
- f) weight of stylus system and/or probing system;
- g) location, type, number of thermal sensors.

5.3 Length measurement error, E_L

The length measurement errors (E_L values) shall not exceed the maximum permissible error of length measurement, $E_{L, MPE}$, as stated by:

- the manufacturer, in the case of acceptance tests;
- the user, in the case of reverification tests.

The length measurement errors (E_L values) and the maximum permissible error of length measurement, $E_{L, MPE}$, are expressed in micrometres.

NOTE The default values of L are 0 mm and 150 mm; hence, $E_L = E_0$ and $E_L = E_{150}$.

5.4 Repeatability range of the length measurement error, R_0

The repeatability range of the length measurement errors (R_0 values) shall not exceed the maximum permissible limit of the repeatability range, $R_{0, MPL}$, as stated by:

- the manufacturer, in the case of acceptance tests;
- the user, in the case of reverification tests.

The repeatability range of the length measurement error (R_0 values) and the maximum permissible limit of the repeatability range, $R_{0, MPL}$, are expressed in micrometres.

5.5 Workpiece loading effects

The length measurement error with $L = 0$ (or minimum required for clearance), E_0 , shall not exceed the maximum permissible error, $E_{0, MPE}$, as stated by the manufacturer when the CMM is loaded with up to the maximum workpiece mass for which the CMM performance is rated. Testing of the length measurement error, E_0 , may be conducted under any workpiece load (from zero up to the rated maximum workpiece load), selected by the user subject to the following conditions:

- the physical volume of the load supplied for testing shall lie within the measuring volume of the CMM and the load shall be free-standing;

- the manufacturer may specify a limit on the maximum load per unit area (kg/m^2) on the CMM support (i.e. table) surface and/or on individual point loads (kg/cm^2); for point loads, the load at any specific contact point shall be no greater than twice the load of any other contact point;
- unless otherwise specified by the manufacturer, the load shall be located approximately centrally and approximately symmetrically at the centre of the CMM table.

The user and manufacturer should arrange for the availability of the load.

The user and the manufacturer should discuss the loading of the CMM table since access to measurement positions may be impaired by the load.

6 Acceptance tests and reverification tests

6.1 General

6.1.1 Acceptance tests are executed according to the manufacturer's specifications and procedures that are in compliance with this part of ISO 10360. In particular, unless the user supplies the calibrated test length (subject to the restrictions of ISO/TS 23165), the manufacturer may choose the artefact representing the calibrated test length from those described in Annex B and Annex D.

Reverification tests are executed according to the user's specifications and the manufacturer's procedures.

Issues associated with dual ram CMMs are discussed in 6.6.

6.1.2 This part of ISO 10360 does not explicitly apply to CMMs using optical probing; however, if, by mutual agreement, the parties apply this approach to optical CMMs, then additional issues, such as the following, should be considered:

- in the case of two dimensional sensors (no ram movement), an index 2D may be used for indication, e.g. E_{0-2D} ;
- in the case of two dimensional systems, the number and location of the measurement positions may be reduced;
- specifications for the magnification and illumination;
- artefact issues such as material and surface finish that affect the test results;
- bidirectional probing may or may not be possible depending on the artefact and probing system (see Annex B).

6.2 Principle

The principle of the assessment method is to use a calibrated test length, traceable to the metre, to establish whether the CMM is capable of measuring within the stated maximum permissible error of length measurement for a CMM with a specified ram axis stylus tip offset (both 0 and 150), E_0 , MPE and E_{150} , MPE, and within the stated maximum permissible limit for the repeatability range, R_0 , MPL.

The assessment shall be performed by comparison of the indicated values of five different calibrated test lengths, each measured three times, relative to their calibrated values. The indicated values are calculated by point-to-point length measurements projected onto the alignment direction (see also Annex C).

Each of the three repeated measurements is to be arranged in the following manner: if one end of the calibrated test length is labelled "A" and the other end "B", then the measurement sequence is either $A_1 B_1$, $A_2 B_2$, $A_3 B_3$ or $A_1 B_1$, $B_2 A_2$, $A_3 B_3$. Other sequences such as $A_1 A_2 A_3$, $B_1 B_2 B_3$ are not permitted. Each of the three repeated measurements shall have its own unique measured points. That is, in general, B_1 , B_2 and

B_3 shall be different actual points of the same target point B. Once the measurement sequence for a test length has begun, no additional probing points shall be measured other than those required to measure its length; for instance, no alignment points are permitted between the measurement of A_1 and B_3 .

For CMMs without workpiece thermal expansion compensation, the uncorrected differential thermal expansion between the CMM and the calibrated test length can produce a significant error; hence this part of ISO 10360 also requires the disclosure of the test length CTE.

For CMMs with workpiece thermal expansion compensation, this thermally induced error is greatly reduced. For these CMMs, a significant portion of the residual thermal error is due to the uncertainty in the test length's CTE (i.e. resulting in imperfect thermal expansion correction); hence this part of ISO 10360 requires the disclosure of the uncertainty in the CTE of the test length.

6.3 Length measurement error with zero ram axis stylus tip offset, E_0

6.3.1 General

The E_0 test shall be conducted using a ram axis stylus tip offset of zero or as small as practical. It is recognized that depending on the CMM type, the artefact used as a calibrated test length, and the particular measurement line, a non-zero ram axis stylus tip offset may be required in order to access the gauging points of the calibrated test length. For these measurement situations, the smallest ram axis stylus tip offset practical shall be used.

NOTE See Figure 1 for examples of ram axis stylus tip offsets, including some small, non-zero offsets.

Prior to beginning the extensive testing described in the following sections, it is recommended to perform the single- or multiple-stylus probing system test, as appropriate, described in ISO 10360-5, to quickly ensure that the probing system is operating within specifications (see also Annex E).

6.3.2 Measuring equipment

The longest calibrated test length for each position shall be at least 66 % of the maximum travel of the CMM along a measurement line through the calibrated test length. Hence the minimum allowable longest calibrated test length positioned along a body diagonal will be longer than the minimum allowable longest calibrated test length positioned along an axis direction. Each calibrated test length shall differ significantly from the others in length. Their lengths shall be well distributed over the measurement line. In general, the five calibrated test lengths used in one position may differ in their lengths from those used in another position, for example due to the extent of CMM travel along different measurement lines.

EXAMPLE 1 An example of well-distributed calibrated test lengths over a 1 m measurement line is: 100 mm, 200 mm, 400 mm, 600 mm, 800 mm.

The manufacturer shall state the upper, and optionally lower, limits of the CTE of the calibrated test length. The manufacturer may calibrate the CTE of a calibrated test length. The manufacturer shall specify the maximum permissible ($k = 2$) uncertainty of the CTE of the calibrated test length. In the case where the calibrated test length is composed of a unidirectional length and a short gauge block (see Annex B), the CTE shall be considered to be that of the unidirectional length. The default for a calibrated test length is a normal CTE material unless the manufacturer's specifications explicitly state otherwise.

If the calibrated test length is not a normal CTE material, then the corresponding $E_{0, MPE}$ values are designated with an asterisk (*) and an explanatory note shall be provided describing the CTE of the calibrated test length.

EXAMPLE 2

$E_{0, MPE}^*$

* Artefact is super-invar with a CTE no greater than $0,5 \times 10^{-6}/^{\circ}\text{C}$ and with a CTE expanded uncertainty ($k = 2$) no greater than $0,3 \times 10^{-6}/^{\circ}\text{C}$.

If the manufacturer's specification states that the calibrated test lengths will be a non-normal CTE material and the CTE is less than $2 \times 10^{-6}/^{\circ}\text{C}$, then perform an additional measurement as described in 6.3.3.3.

A low CTE test length can be mathematically adjusted to give the apparent behaviour of a normal CTE material test length subject to the requirements of Annex D; however, this calibrated test length is still considered to have a low CTE and is subject to the requirement of 6.3.3.3.

See Annex B for examples of a calibrated test length.

6.3.3 Procedure

6.3.3.1 Measurement positions

Five different calibrated test lengths shall be placed in each of seven different positions (locations and orientations) in the measuring volume of the CMM, and each length shall be measured three times, for a total of 105 measurements. Four of the seven positions shall be the space diagonals, as shown in Table 2. The user may specify the remaining three positions; the default positions are parallel to each of the CMM axes, as shown in Table 2.

Table 2 — Orientation in the measuring volume

Position number	Orientation in the measuring volume	Required or default
1	Along the diagonal in space from point (1, 0, 0) to (0, 1, 1)	Required
2	Along the diagonal in space from point (1, 1, 0) to (0, 0, 1)	Required
3	Along the diagonal in space from point (0, 1, 0) to (1, 0, 1)	Required
4	Along the diagonal in space from point (0, 0, 0) to (1, 1, 1)	Required
5	Parallel to the machine scales from point (0, 1/2, 1/2) to (1, 1/2, 1/2)	Default
6	Parallel to the machine scales from point (1/2, 0, 1/2) to (1/2, 1, 1/2)	Default
7	Parallel to the machine scales from point (1/2, 1/2, 0) to (1/2, 1/2, 1)	Default

NOTE For specifications in this table, opposite corners of the measuring volume are assumed to be (0, 0, 0) and (1, 1, 1) in coordinates (X, Y, Z).

The manufacturer may, at his discretion, specify the maximum permissible error of length measurement with zero ram axis stylus tip offset, for each CMM axis, i.e. positions 5-6-7.

The notation shall be E_{0X} and $E_{0X, MPE}$, E_{0Y} and $E_{0Y, MPE}$, and E_{0Z} and $E_{0Z, MPE}$.

For CMMs with a high aspect ratio between the length of the axes, it is recommended that the manufacturer and the user, upon mutual agreement, add two additional measurement positions. A high aspect ratio CMM occurs when the length of the longest axis is at least three times the length of the intermediate axis. The recommended positions, each consisting of five calibrated test lengths, each measured three times, are the two (corner-to-corner) diagonals in a plane perpendicular to the longest axis, i.e. if X is the longest axis, then the two diagonals are in the Y-Z plane and located approximately at the midpoint of the X axis.

6.3.3.2 Measurement procedure

Set up and qualify the probing system in accordance with the manufacturer's normal procedures (see 5.2). All probing system qualifications shall be performed using the manufacturer-supplied reference sphere (or other artefact supplied by the manufacturer for probe qualifications in the normal use of the CMM) and shall not make use of any test artefact or other artefacts. The ram axis stylus tip offset should be zero (or the minimum value to allow clearance) to measure the calibrated test length.

For each of the five calibrated test lengths, obtain three measurement results. See Annex B for details regarding the measurement procedure for specific types of test lengths. Repeat for all seven measurement positions for a total of 105 measurement results from the calibrated test lengths.

Supplementary measurements may be required for artefact alignment purposes. It is recommended that the alignment method used be consistent with the procedures used for the artefact calibration.

The manufacturer should clearly specify on the data sheet the stylus system that will be used for the E_0 test; for example, a straight 20 mm long stylus shall be used in the test. If the manufacturer does not specify the stylus system, the user is free to choose the system from any stylus components supplied with the CMM.

NOTE Changing the stylus system may significantly change the E_0 test results.

6.3.3.3 Low CTE case

For the case where the manufacturer's specification for $E_{0, \text{MPE}}$ requires $\alpha < 2 \times 10^{-6}/^\circ\text{C}$ (thus being a non-normal CTE), an additional measurement shall be performed on a normal CTE material calibrated test length. The normal CTE material test length shall be greater than the lesser of 0,5 m or 50 % of the longest CMM axis travel. This measurement shall be performed in the centre of the CMM measuring volume and parallel to one of the CMM axes. The measurement shall be repeated three times. The manufacturer may calibrate the CTE of this test length.

NOTE 1 When a laser interferometer is used to produce the calibrated test lengths, as described in Annex B, the laser interferometer is considered a low CTE material and hence requires the measurement of a normal CTE calibrated test length.

NOTE 2 When using a laser interferometer, it is good practice to measure the normal CTE artefact along a measurement line that was previously measured using the laser interferometer. The consistency of the errors of indication from the laser interferometer and from the normal CTE artefact serves as a quick check to see if the compensation for the workpiece CTE and the compensation for the index of refraction have been correctly implemented.

6.3.4 Derivation of test results

For all 105 measurements, and (if required) the three additional measurements of 6.3.3.3, calculate each length measurement error, E_0 , by calculating the difference between the indicated value and the calibrated value of each test length (where the calibrated value is taken as the conventional true value of the length). The indicated value of a particular measurement of a calibrated test length may be corrected by the CMM to account for systematic errors, or thermally induced errors (including thermal expansion) if the CMM has accessory devices for this purpose. Manual correction of the results obtained from the computer output to account for temperature or other corrections shall not be allowed when the environmental conditions satisfy the conditions of 5.1.

NOTE For some CMMs, the thermal correction system requires the user to input values of the artefact's CTE and temperature as part of its automatic thermal compensation system as described in its operating documentation. This is permitted provided it is the CMM software that performs the thermal compensation. Manual thermal compensation by the user is not permitted.

Plot all length measurement errors (E_0 values) on a diagram, as indicated on the figure (Figure 12, Figure 13 or Figure 14 of ISO 10360-1:2000) that matches the expressed form of $E_{0, \text{MPE}}$.

6.4 Repeatability range of the length measurement error, R_0

For each set of three repeated measurements in 6.3, calculate the repeatability range, R_0 , by evaluating the range of the three repeated length measurements.

Plot all the repeatability range values (R_0 values) on a diagram, as indicated on the figure (Figure 12, Figure 13 or Figure 14 of ISO 10360-1:2000) that matches the expressed form of $R_{0, \text{MPL}}$.

6.5 Length measurement error with ram axis stylus tip offset of 150 mm, E_{150}

6.5.1 Measuring equipment

The longest calibrated test length for each position shall be at least 66 % of the maximum travel of the CMM along a line through the calibrated test length.

Each calibrated test length shall differ significantly from the others in length. Their lengths shall be well distributed over the measurement line. In general, the five calibrated test lengths used in one position may differ in their lengths from those used in another position, for example due to the extent of CMM travel along different measurement lines.

EXAMPLE 1 An example of well-distributed calibrated test lengths over a 1 m measurement line is: 100 mm, 200 mm, 400 mm, 600 mm, 800 mm.

The default for the calibrated test length is a normal CTE material unless the manufacturer's specifications explicitly state otherwise. The manufacturer shall state the upper, and optionally lower, limit of the CTE of the calibrated test length. The manufacturer may calibrate the CTE of a calibrated test length. The manufacturer shall specify the maximum permitted ($k = 2$) uncertainty of the CTE of the calibrated test length.

If the calibrated test length is not a normal CTE material, then the corresponding $E_{150, MPE}$ values are designated with an asterisk (*) and an explanatory note shall be provided describing the CTE of the calibrated test length.

EXAMPLE 2

$E_{150, MPE}^*$

* Artefact is super-invar with a CTE no greater than $0,5 \times 10^{-6}/^{\circ}\text{C}$ and with a CTE expanded uncertainty ($k = 2$) no greater than $0,3 \times 10^{-6}/^{\circ}\text{C}$.

See Annex B for examples of a calibrated test length.

6.5.2 Procedure

6.5.2.1 Probe orientations

Set up and qualify the probing system in accordance with the manufacturer's normal procedures (see 5.2). All probing system qualifications shall be performed using the manufacturer-supplied reference sphere (or other artefact supplied by the manufacturer for probe qualifications in the normal use of the CMM) and shall not make use of any test artefact or other artefacts.

The default value for the ram axis stylus tip offset is 150 mm (± 15 mm), i.e. E_{150} .

The direction of the ram axis stylus tip offset is to be oriented perpendicular to the measurement line defined by the calibrated test length and pointing along a CMM axis direction.

For each measurement, the user may specify the direction of the ram axis stylus tip offset to be pointing either in the positive or in the negative axis direction, i.e. in either the +X or -X direction for positions 1A or 1B, and in either the +Y or -Y direction for positions 2A or 2B (see Figure 2). Hence, of the eight possible combinations of test length positions and probe orientations, the user may choose any two for testing.

6.5.2.2 Possible measurement positions and probe orientations

Unless otherwise specified (see 6.5.2.3, Note 3), only two of the eight possible combinations of calibrated test length positions and probe orientations are to be tested.

The user may specify either one or two calibrated test length positions from the four positions shown in Table 3.

The user may specify one or two of the probe orientations described in 6.5.2.1.

If only one test length position is specified, then the probe orientations shall be diametrically opposite as described in 6.5.2.1 and 6.5.2.3, Note 4.

If the ram axis of the CMM is designated other than the Z axis, then corresponding changes shall be made to the positions and probe orientations in Table 3.

Table 3 — Orientation in the measuring volume

Position number	Orientation in the measuring volume
1A	Along the YZ plane diagonal from point (1/2, 0, 0) to (1/2, 1, 1)
1B	Along the YZ plane diagonal from point (1/2, 0, 1) to (1/2, 1, 0)
2A	Along the XZ plane diagonal from point (0, 1/2, 0) to (1, 1/2, 1)
2B	Along the XZ plane diagonal from point (0, 1/2, 1) to (1, 1/2, 0)
NOTE For specifications in this table, opposite corners of the measuring volume are assumed to be (0, 0, 0) and (1, 1, 1) in coordinates (X, Y, Z).	

NOTE For very small CMMs, it may be necessary to translate the calibrated test length, keeping it oriented along an XZ or YZ diagonal, in order to provide sufficient clearance for measurement, e.g. position 1A could be from point (1, 0, 0) to (1, 1, 1).

6.5.2.3 Measurements

For each combination of test length position and probe orientation, five different calibrated test lengths shall be measured three times each. Hence, for the two selected combinations, a total of 30 measurements shall be performed. See Annex B for details regarding the measurement procedure for specific types of test lengths. Supplementary measurements may be required for artefact alignment purposes. It is recommended that the alignment method used be consistent with the procedures used for the artefact calibration (see Annex C).

NOTE 1 Manufacturers may specify values of $E_{L, MPE}$ for other ram axis stylus tip offset values, L , particularly for large CMMs where large stylus tip offsets are frequently used. Users with specific measurement needs may, by agreement with the manufacturer, obtain specifications of $E_{L, MPE}$ for specific values of L .

NOTE 2 For purposes of specification, the stylus tip offset default value is 150 mm (± 15 mm); however, in order to demonstrate conformance with specifications, the manufacturer may, at his discretion, use a longer stylus if it is convenient to do so.

NOTE 3 Although only two of the eight possible combinations of test length positions and probe orientations are tested, additional testing may be performed with mutual agreement between the manufacturer and the user.

NOTE 4 It is often advantageous to select a single position and perform the test with both (diametrically opposite) probe orientations for the E_{150} test. The difference between the two errors of indication (measured with diametrically opposite probe orientations) is a measure of the effective angular rotation associated with the use of a probe with a ram axis stylus tip offset of 150 mm in that position.

The position of the stylus tip, in the direction along the ram axis, should also be significantly different from that used for the E_0 test. The difference in position along the ram axis should preferably be the same, if allowed by the CMM travel, as the ram axis stylus tip offset, and may be in either direction (+ or -) along the ram axis. See 3.1 and Figure 1 showing different ram axis stylus tip offsets resulting in significantly different stylus tip locations along the ram axis.

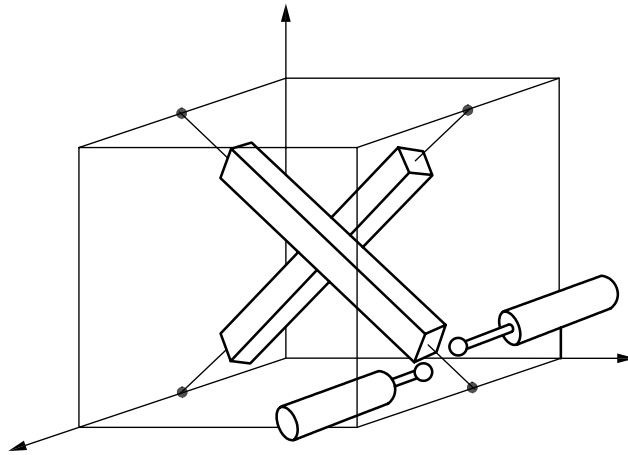

Figure 2 — Example showing two of the four possible calibrated test length positions, and two of the four possible probe orientations for the E_{150} test procedure

6.5.3 Derivation of test results

For all 30 measurements, calculate each length measurement error, E_{150} , by calculating the difference between the indicated value and the calibrated value of each test length (where the calibrated value is taken as the conventional true value of the length). The indicated value of a calibrated test length may be corrected to account for systematic errors, or thermally induced errors (including thermal expansion) if the CMM has accessory devices for this purpose. Manual correction of the results obtained from the computer output to account for temperature or other corrections shall not be allowed when the environmental conditions satisfy the conditions of 5.1.

NOTE For some CMMs, the thermal correction system requires the user to input values of the artefact's CTE and temperature as part of its automatic thermal compensation system as described in its operating documentation. This is permitted provided it is the CMM software that performs the thermal compensation. Manual thermal compensation by the user is not permitted.

Plot all the length measurement errors (E_{150} values) on a diagram, as indicated on the figure (Figure 12, Figure 13 or Figure 14 of ISO 10360-1:2000) that matches the expressed form of E_{150} , MPE.

6.6 Dual ram CMMs

6.6.1 Simplex operating mode

The performance of the individual ram machines shall be specified for the simplex operating mode. The simplex operating mode is specified by the procedures in 6.3, 6.4, and 6.5, treating the individual ram machine similar to a single ram CMM. The measuring volume of a single ram used in the simplex mode is defined by the volume accessible by the individual ram using minimal probe and stylus extensions.

6.6.2 Duplex operating mode

6.6.2.1 A CMM used in duplex operating mode shall follow the procedures in 6.3, 6.4, and 6.5 with the following modifications.

6.6.2.2 Before beginning the testing procedure, it is good practice to place a test sphere near the centre of the measuring volume and measure the location of the sphere with each ram. The distance between the two sphere centre locations should be less than $E_{0, MPE}$ for a zero length artefact; this quickly ensures that the two rams are properly qualified.

One end of each calibrated test length shall be measured with probing from one ram and the opposite end of that calibrated test length shall be measured with probing from the other ram.

It is recommended that the midpoint of each calibrated test length be located away from the centre plane between the two rams.

6.6.2.3 Some errors of the individual rams are nearly equal when their distances from the centre plane are symmetrical. This can lead to cancellation of the effect of these errors when measuring lengths in the duplex operating mode if the two ends of the calibrated test length are located at equal distances from the centre plane. Displacing the calibrated test lengths' midpoints away from the centre plane reduces the tendency of these symmetric errors to cancel each other out. For example, when using a laser interferometer, this may easily be done by extending both rams approximately to the centre of the measuring volume, then by alternating retracting movements of one arm by one third of its travel with retracting movements of the other arm by one half of that arm's travel to achieve the five required test lengths spanning at least 66 % of maximum travel.

If a laser interferometer is used to produce calibrated test lengths without contact probing (analogous to B.3.3.4), then the retroreflector shall be attached to one ram and the interferometer attached to the other ram, with the laser beam determining the measurement line. Each ram shall be moved to the ends of the required five calibrated test lengths for that measurement line. To satisfy the requirements of Clause B.3 and to verify the metrological link between the two rams, each arm shall measure one point on the end of the short gauge block, repeated three times, for each measurement line.

A laser interferometer is considered a low CTE material (see Annex B) and is subject to the requirements in 6.3.3.3.

To avoid ambiguity, specifications of the MPE and MPL values of dual ram CMMs shall be clearly stated as either "simplex operating mode" or "duplex operating mode".

7 Compliance with specifications

7.1 Acceptance test

7.1.1 Acceptance criteria

The performance of the CMM used for measuring linear dimensions is verified if

- the length measurement errors measured with zero ram axis stylus tip offset (E_0 values) are within the maximum permissible error of length measurement, $E_{0, MPE}$, as specified by the manufacturer when plotted on the appropriate diagram as indicated on Figure 12, Figure 13 or Figure 14 of ISO 10360-1:2000, and taking into account the uncertainty according to ISO 14253-1 and ISO/TS 23165,

and

- the repeatability range of the length measurement error (R_0 values) are within the maximum permissible limit of the repeatability range, $R_{0, MPL}$, as specified by the manufacturer when plotted on the appropriate diagram as indicated on Figure 12, Figure 13 or Figure 14 of ISO 10360-1:2000, and taking into account the uncertainty according to ISO 14253-1 and ISO/TS 23165,

and

- the length measurement error measured with ram axis stylus tip offset 150 mm (E_{150} values) are within the maximum permissible error of length measurement, $E_{150, MPE}$, as specified by the manufacturer when plotted on the appropriate diagram as indicated on Figure 12, Figure 13 or Figure 14 of ISO 10360-1:2000, and taking into account the uncertainty according to ISO 14253-1 and ISO/TS 23165.

For CMMs that are not intended for use with a ram axis stylus tip offset or CMMs not capable of being used with a ram axis stylus tip offset of any length L , verification of the length measurement error, E_L , is not required.

7.1.2 Data rejection and repeated measurements

7.1.2.1 Length measurement error with zero ram axis stylus tip offset, E_0

A maximum of five of the 35 sets (or 36 sets if 6.3.3.3 is required) of three repeated measurements in accordance with 6.3 may have one (and no more than one) of the three values of the length measurement error outside the conformance zone.

Each such measurement that is outside the conformance zone (according to ISO 14253-1) shall be re-measured three times at the relevant position.

If all the values of the errors of indication of a calibrated test length with zero ram axis stylus tip offset from the three repeated measurements are within the conformance zone (see ISO 14253-1), then the performance of the CMM is verified at that position.

7.1.2.2 Repeatability range of the length measurement error, R_0

If a calibrated test length is re-measured according to 7.1.2.1, then the range of the three repeated measurements shall be used to determine R_0 at that position, and the three original measurements shall be discarded.

No additional repeated measurements (beyond that allowed by 7.1.2.1) shall be performed.

7.1.2.3 Length measurement error with ram axis stylus tip offset of 150 mm, E_{150}

A maximum of two of the 10 sets of three repeated measurements in accordance with 6.5 may have one (and no more than one) of the three values of the length measurement error outside the conformance zone.

Each such measurement that is out of the conformance zone (according to ISO 14253-1) shall be re-measured three times at the relevant position.

If all the values of the errors of indication of a calibrated test length with ram axis stylus tip offset of 150 mm from the three repeated measurements are within the conformance zone (see ISO 14253-1), then the performance of the CMM is verified at that position.

7.2 Reverification test

The performance of the CMM used for measuring linear dimensions is considered to have been reverified if E_0 , R_0 , and E_{150} , described in 6.3, 6.4 and 6.5, are not greater than the maximum permissible errors, E_0 , MPE, E_{150} , MPE, and maximum permissible limit, R_0 , MPL, as determined in 7.1.

8 Applications

8.1 Acceptance test

In a contractual situation between a manufacturer and a user such as that described in a

- purchasing contract,
- maintenance contract,
- repair contract,
- renovation contract, or
- upgrading contract,

the acceptance test specified in this part of ISO 10360 may be used as a test for verifying the performance of the CMM used for measuring linear dimensions in accordance with the specification for the stated maximum permissible errors, $E_{0, MPE}$, $E_{L, MPE}$, and maximum permissible limit, $R_{0, MPL}$, as agreed upon by the manufacturer and the user.

The manufacturer is permitted to specify detailed limitations applicable for $E_{0, MPE}$, $R_{0, MPL}$, and $E_{150, MPE}$. If no such specification is given, $E_{0, MPE}$, $R_{0, MPL}$, and $E_{150, MPE}$ apply for any location and orientation in the measuring volume of the CMM.

8.2 Reverification test

In an organization's internal quality assurance system, the performance verification described in this part of ISO 10360 can be used as a reverification test to verify the performance of the CMM used for measuring linear dimensions in accordance with the specification for the maximum permissible errors, $E_{0, MPE}$, $E_{150, MPE}$, and maximum permissible limit, $R_{0, MPL}$, as stated by the user. The user is permitted to state the values of, and to specify detailed limitation applicable to, $E_{0, MPE}$, $R_{0, MPL}$, and $E_{150, MPE}$.

NOTE 1 The tester accounts for the test uncertainty according to ISO 14253-1; accordingly, a reverification test (where, typically, the tester is the user) may have a different conformance zone than an acceptance test.

NOTE 2 In acceptance testing, the conformance zone is derived from the manufacturer's specifications. In reverification testing, the reverification limits may be derived from the user's metrological needs.

8.3 Interim check

In an organization's internal quality assurance system, a reduced performance verification may be used periodically to demonstrate the probability that the CMM conforms with specified requirements regarding the maximum permissible errors, $E_{0, MPE}$, $E_{150, MPE}$, and maximum permissible limit, $R_{0, MPL}$. The extent of the performance verification as described in this part of ISO 10360 may be reduced by using fewer measurements and positions (see Annex A).

NOTE This part of ISO 10360 is primarily concerned with acceptance and reverification testing. Interim testing is often associated with quality assurance. See the ISO/TS 15530 series of documents for further discussion of the role of measurement uncertainty associated with CMM measurements.

9 Indication in product documentation and data sheets

The symbols of Clause 4 are not suitable for use in product documentation, drawings, data sheets, etc. Table 4 gives the corresponding indications which are also allowed.

Table 4 — Symbols and corresponding indications in product documentation, drawings, data sheets, etc.

Symbol used in this document	Corresponding indication
E_L	EL
R_0	RO
$E_{L, MPE}$	$MPE(EL)$
$R_{0, MPL}$	$MPL(RO)$

Annex A (informative)

Interim check

A.1 Interim check of the CMM

It is strongly recommended that the CMM be checked regularly during the periods between periodic reverification. The interval between checks should be determined from the environmental conditions and the measuring performance required. The CMM should be checked immediately after any significant event that can have affected CMM performance.

Artefacts other than those calibrated test lengths that are described in Annex B may also be used in the interim test. The measurements should be made directly after the performance verification test; the positions and orientations of the artefacts should be noted and subsequently repeated.

Depending on the measurement tasks for which the CMM is used, the most relevant of the following commonly used artefacts should be chosen; some examples are given below:

- a purpose-made test piece that has features representing typical geometrical shapes, is dimensionally stable, mechanically robust, and which has a surface finish that does not significantly affect the uncertainty of measurement;
- a ball plate;
- a hole plate;
- a ball bar;
- a hole bar;
- a bar that can be kinematically located between a fixed reference sphere and the CMM probe-stylus sphere;
- a circular artefact (e.g. a ring gauge).

It is strongly recommended that the artefact material have a CTE similar to typical workpieces measured with the CMM.

The method involving the mathematical adjustment to low CTE artefacts described in Annex D may be used in interim testing; however, it is crucial that the temperature of the low CTE artefact used for the adjustment be measured with an independent thermometer that is not part of the CMM.

A.2 Interim testing and the comparison to specifications

A.2.1 General

In some cases, it may be desirable to perform an interim test such that the results can be compared to the manufacturer's specifications for $E_{0, MPE}$, R_0 , MPL and $E_{L, MPE}$. In this case, a calibrated test length, as described in Annex B, should be used and the measurement procedures described in this part of ISO 10360 followed.

In order to minimize the time to perform the interim test an abbreviated test procedure should focus on those test positions that most commonly reveal a problem with the CMM. For example, the measurement of a single long test length in each of the body diagonals will generally more readily reveal CMM errors than the measurements of five test lengths along a CMM axis.

Each of the errors of indication from the interim test should be less than the corresponding specification, e.g. E_0 , MPE , provided the test is conducted according to the procedures of this part of ISO 10360 and the environmental conditions are within those stated by the manufacturer.

A.2.2 Interim testing using unidirectional artefacts

In the case where unidirectional artefacts are employed in the interim test, where minimizing the amount of testing time is important, and where comparison to the manufacturer's specifications is desired, the following procedure is useful. In this procedure, the short gauge block measurements that are normally required when producing a calibrated test length using a unidirectional artefact are replaced by a combination of a single stylus form measurement, P_{FTU} , and the corresponding error of indication of sphere size, P_{STU} , as described in ISO 10360-5 as shown below. The measured values of P_{FTU} and P_{STU} should be measured as part of the interim test. For $L = 0$ mm or $L = 150$ mm:

- if the unidirectional error is greater than or equal to zero, then E_L is approximated by the unidirectional error plus ($P_{FTU} + |P_{STU}|$);
- if the unidirectional error is less than zero, then E_L is approximated by the unidirectional error minus ($P_{FTU} + |P_{STU}|$).

This method of determining the error of indication is an approximation to the method specified in Clause 6 and may overestimate the error. If an error of indication in the interim test exceeds its corresponding MPE value, then the position should be re-measured using the procedures specified in Clause 6.

This method is not recommended for the case of laser interferometry without contact probing measured in a unidirectional manner (see B.3.3.4) because insufficient information is available to adjust the repeatability range value (see below). The two probing test results used in this method should be applicable to the stylus used to measure the unidirectional length.

When using this method to compare with the manufacturer's specifications for repeatability range, i.e. R_0 , MPL , calculate the R_0 values as described below.

For step gauges measured in a unidirectional manner (see B.3.3.1), the repeatability range, R_0 , is calculated by evaluating the range of the three repeated unidirectional length measurements and multiplying by 1,73. This also applies to laser interferometry with contact probing measured in a unidirectional manner (see B.3.3.3) when the gauging surface is a plane.

NOTE 1 The multiplication factor of 1,73 compensates for the averaging of three measured points per side during the length measurement and the absence of the short gauge block measurements.

For ball plates and ball bars measured in a unidirectional manner (see B.3.3.2), the repeatability range, R_0 , is calculated by evaluating the range of the three repeated unidirectional length measurements and multiplying by 1,41. This also applies to laser interferometry with contact probing measured in a unidirectional manner (see B.3.3.3) when the gauging surface is a sphere measured with five probing points.

NOTE 2 The multiplication factor of 1,41 compensates for the fact that each centre point is derived from five specified measured points and the absence of the short gauge block measurements.

Annex B (normative)

Artefacts that represent a calibrated test length

B.1 General

For economy availability and practicality, it is the intent of this part of ISO 10360 to allow several types of artefacts to be used in testing a CMM provided they are appropriately adjusted (as described in this annex) to yield the same measurand, a calibrated test length.

A calibrated test length, as measured by the procedures of this part of ISO 10360, is designed to detect three categories of CMM errors:

- 1) geometrical and thermal errors associated with the CMM between the two endpoints of the test length;
- 2) stylus tip size errors;
- 3) repeatability problems as evaluated, in effect, by a single probing point on each end of the calibrated test length.

Clauses B.2 and B.3 describe common artefacts that may be used as a calibrated test length.

In some cases, these artefacts may not be available or sufficiently long, particularly when testing very large CMMs. In this case, both parties may agree to use other means to generate a calibrated test length. These might include length standards that are "stitched" together (i.e. overlapped end-to-end) to form a longer artefact, or other types of laser-based lengths, e.g. produced by multilateration. In the latter case, issues associated with the absence of contact probing shall be accounted for (see Clause B.3). In all such cases, the procedure shall be documented and the uncertainties associated with these techniques shall be considered carefully.

A laser interferometer that is corrected for the index of refraction of air has a zero CTE ($\alpha = 0$). Hence, if it is used to produce a calibrated test length, it is considered a low CTE material and is subject to the requirements of 6.3.3.3. Additionally, if the laser has a workpiece (material) temperature sensor, then the workpiece CTE in the laser's software shall be set to 0. If a laser is used on a temperature-compensated CMM, then the workpiece CTE in the CMM's software shall be set to 0.

When a laser interferometer is used to produce a calibrated test length, the CMM shall be positioned at a point described by nominal coordinates, without probing a surface. In this case, some CMMs may not arrive at the nominal position exactly. This does not necessarily result in an error of indication as long as the CMM reports the actual position. Consequently, for each test length, the spatial distance between the reported CMM coordinates of points A and B shall be evaluated and compared with the distance indicated by the laser interferometer. It has to be ensured that the CMM coordinates used for the calculation of the error include all compensations that would be considered during the probing process.

Some artefacts such as step gauges, multi-ball ball bars, ball plates, and laser interferometry can produce multiple lengths relative to a "reference zero". For example, a step gauge can measure lengths "A" to "B", "A" to "C", etc., or an interferometer can measure the displacement from an initial position to a series of subsequent positions (each of different length). In order to provide equivalency to gauge blocks, the reference position, i.e. the "zero", shall be re-measured each time a calibrated test length is produced. That is, the "A" to "B" length and the "A" to "C" length must each have its own "A" measured anew. Similarly, with interferometry, the initial position shall be re-measured for each displacement used to produce a calibrated test length.

B.2 Bidirectional measurements

B.2.1 General

Bidirectional measurements of calibrated gauges represent a calibrated test length. A bidirectional measurement involves probing a single point on each end of the gauge, and approaching these probing points from diametrically opposite directions (see Figure B.1). Internal and external bidirectional measurements shall not be mixed on a measurement line. Several possible bidirectional measurement methods are described below.

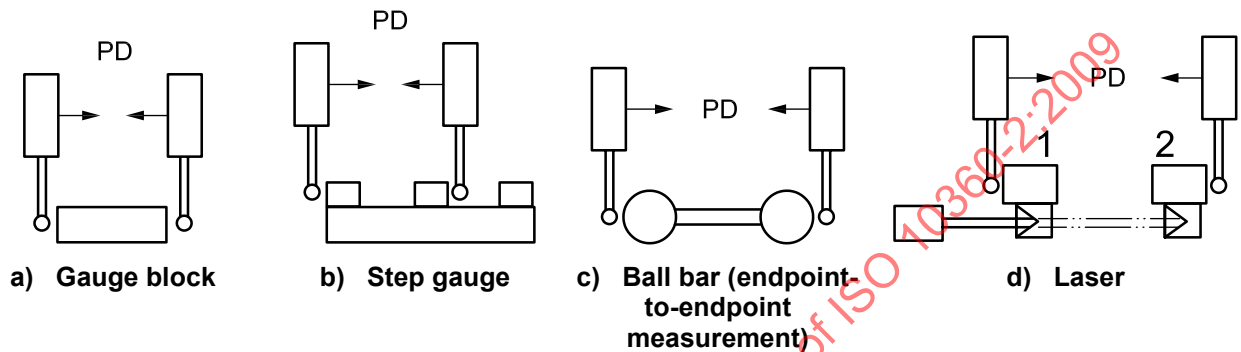

Key

- PD probing direction
- 1 position 1
- 2 position 2

Figure B.1 — Examples of bidirectional measurements, each probed with a single point in each direction

B.2.2 Gauge blocks

A calibrated test length may be produced using a calibrated gauge block measured with a single-point-to-single-point method. It is advised that each probing point be located at the calibrated gauging point for the block. See Annex C for alignment procedures.

B.2.3 Step gauges measured in a bidirectional manner

A calibrated test length may be produced using a calibrated step gauge measured with a single-point-to-single-point bidirectional method (see Figure B.1). See Annex C for alignment procedures.

B.2.4 Ball bars/ball plates measured in a bidirectional manner

A calibrated test length may be produced using a ball bar/ball plate where the length is equal to the calibrated sphere centre-to-centre length plus one half of the calibrated diameter of each sphere. The gauge is measured in a single-point-to-single-point bidirectional manner (identical to a gauge block). See Annex C for alignment procedures.

B.2.5 Laser interferometry with contact probing measured in a bidirectional manner

A calibrated test length can be produced using a laser interferometer and a gauge block. The calibrated test length is the sum of the calibrated length of the gauge block and the displacement recorded by a calibrated laser interferometer system. The gauge block is measured with a single point at the initial position. Then the opposite face of the gauge block is measured with a single point at the second position (see Figure B.1).

B.3 Unidirectional measurements (shall be supplemented with bidirectional measurements)

B.3.1 General

For purposes of this part of ISO 10360, unidirectional measurements are any measurements that are not bidirectional. They include step gauges measured in a unidirectional manner, centre-to-centre distances of ball plates and ball bars, and some methods of laser interferometry (see Figure B.2).

Unidirectional measurements shall be combined with bidirectional measurements in order to produce a calibrated test length for testing purposes of this part of ISO 10360.

A calibrated test length can be produced using the arithmetic sum of a calibrated unidirectional length and a calibrated bidirectional length (default is a short gauge block) with the bidirectional length measured in a single point-to-single-point manner.

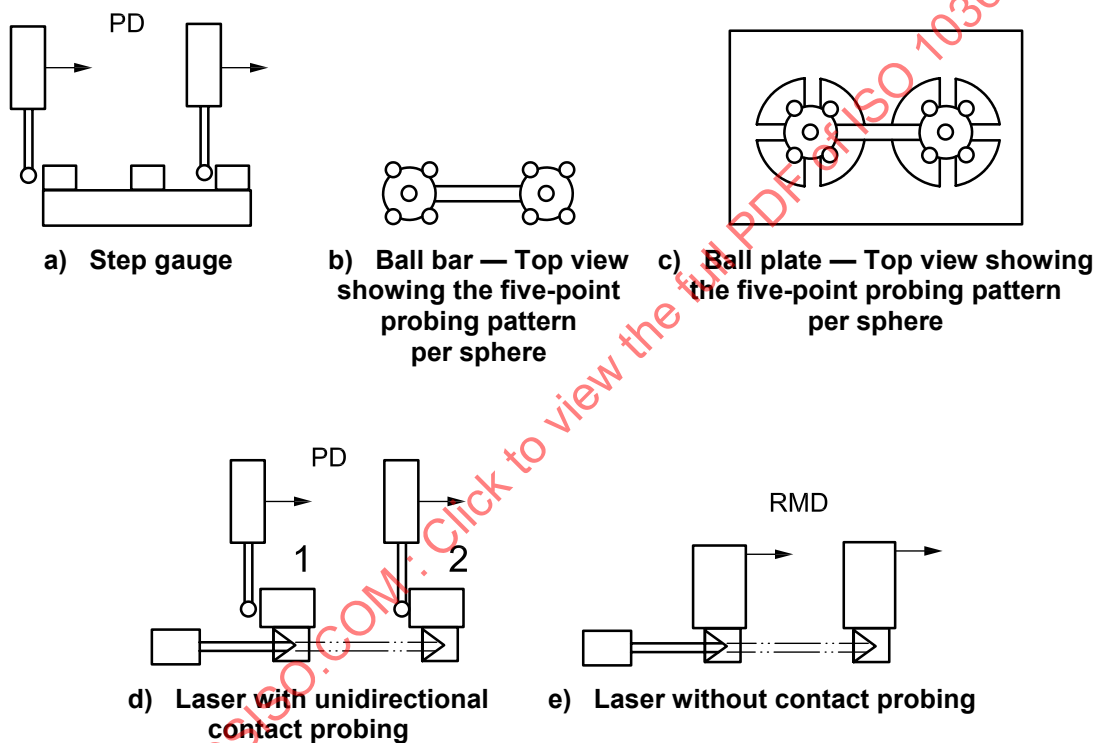

- Key**
- PD probing direction
 - RMD ram motion direction
 - 1 position 1
 - 2 position 2

Figure B.2 — Examples of unidirectional measurements

B.3.2 Calibrated test length composed of unidirectional and short gauge block measurements

For each measurement line under test (there are seven lines for the E_0 test and up to two lines out of a possible four lines for the E_{150} test), measure a short (default 25 mm) calibrated gauge block in a bidirectional manner as described in B.2.2.

The gauge block shall be oriented along the measurement line, i.e. the gauge block axis shall be approximately in the same direction as the measurement line under test. The location of the gauge block shall be as close as possible to the measurement line under test; however, for ease of fixturing, the block may be located near the CMM table surface.

For example, if a body diagonal of the CMM is the measurement line under test, then the gauge block shall be oriented along the direction of the body diagonal, but may be located "beneath" the diagonal and fixtured near the table surface.

The short gauge block shall be measured a total of three times and the errors of indication recorded in their chronological order. In the special case of the E_{150} test, when the same measurement line is measured with two diametrically oriented probes, the three short gauge block measurements shall be measured with one probe orientation, then repeated with the opposite probe orientation.

For each of the five lengths (per measurement line), measure a calibrated unidirectional length three times and record the errors of indication in chronological order; details for specific types of unidirectional lengths are described in B.3.3.

To each of the three unidirectional errors of indication add (in the usual arithmetical manner) the chronologically corresponding bidirectional errors of indication to create the errors of indication of the calibrated test lengths. Repeat for all five lengths per measurement line; this involves a total of 15 unidirectional measurements and three bidirectional short gauge block measurements per measurement line.

NOTE The test results are affected by the position of the short gauge block; for instance, locating the gauge block near the CMM table may alter the test performance due to the CMM behaviour when the ram is fully extended. The intended representation of the CMM performance is approximated by locating the short gauge block in the middle of the measuring line. However, this may cause fixturing problems. It is up to the tester to choose the best compromise.

An alternative to the short gauge block is to measure a small sphere of calibrated diameter (default of 25 mm) in a bidirectional manner as follows. Two points shall be located at opposite points of a sphere diameter that is oriented parallel to the measurement line. The other two points shall be spaced 90° apart, located on the sphere and in a plane orthogonal to the measurement line and containing the sphere centre. The sphere diameter measured in this manner is equivalent to a bidirectional short gauge block measurement.

This alternative method may be used upon agreement between the user and manufacturer; otherwise, the short gauge block shall be used.

B.3.3 Artefacts for unidirectional measurements

B.3.3.1 Step gauges measured in a unidirectional manner

A unidirectional measurement of a step gauge shall have each gauging surface measured with three discrete points (at the same target contact point) and the coordinates averaged.

The length is determined using the averaged coordinates. The measurement shall be done in a unidirectional manner (see Figure B.2). See Annex C for alignment procedures.

The averaging of three points on each gauging surface of a unidirectional step gauge is needed, when combined with the short gauge block errors, to have the test results be equivalent to that of the single-point-to-single-point bidirectional measurement case.

B.3.3.2 Ball plates and ball bars measured in a unidirectional manner

A unidirectional measurement of an artefact with spherical gauging surfaces, such as a ball plate or ball bar, consists of each sphere measured with five probing points and the (least squares fit) centre-to-centre length determined.

The point sampling strategy is shown in Figure B.2.

B.3.3.3 Laser interferometry with contact probing measured in a unidirectional manner

A unidirectional measurement can be produced using a calibrated laser interferometer and a gauging surface; the gauging surface may be a plane or a sphere.

The measurement involves interferometrically measuring the displacement of the gauging surface that is (contact) probed by the CMM. The gauging surface is typically moved on a carriage or sled that has an attached laser retroreflector.

In the case where the gauging surface is a sphere, the sphere centre location shall be measured with five points as described in B.3.3.2. In the case of a plane, the surface is probed with three points at each position and the coordinates averaged as described in B.3.3.1; the probing direction is the same for both the initial and final positions (see Figure B.2).

B.3.3.4 Laser interferometry without contact probing measured in a unidirectional manner

In some cases (particularly large CMMs), it may be convenient to replace the probing system with a retroreflector and to measure the displacement of the CMM using laser interferometry.

Each laser displacement measurement is considered a unidirectional measurement (see Figure B.2).

For some CMMs tested with laser interferometry used without contact probing, the interferometric measurements might not appropriately implement the CMM compensation for geometrical errors. Consequently, this will yield an error of indication much larger than would be the case with contact probing. In such cases, a calibrated test length involving contact probing should be employed and an external trigger activating the error compensation may alleviate the problem.

STANDARDSISO.COM : Click to view the full text of ISO 10360-2:2009