

ASME B30.22-2016
(Revision of ASME B30.22-2010)

Articulating Boom Cranes

**Safety Standard for Cableways,
Cranes, Derricks, Hoists, Hooks, Jacks,
and Slings**

ASMENORMDOC.COM : Click to view the full PDF of ASME B30.22-2016

AN AMERICAN NATIONAL STANDARD



**The American Society of
Mechanical Engineers**

ASME B30.22-2016
(Revision of ASME B30.22-2010)

Articulating Boom Cranes

**Safety Standard for Cableways,
Cranes, Derricks, Hoists, Hooks, Jacks,
and Slings**

ASMENORMDOC.COM : Click to view the full PDF of ASME B30.22-2016

AN AMERICAN NATIONAL STANDARD



**The American Society of
Mechanical Engineers**

Two Park Avenue • New York, NY • 10016 USA

Date of Issuance: June 17, 2016

The next edition of this Standard is scheduled for publication in 2021. This Standard will become effective 1 year after the Date of Issuance.

ASME issues written replies to inquiries concerning interpretations of technical aspects of this Standard. Interpretations are published on the ASME Web site under the Committee Pages at <http://cstools.asme.org/> as they are issued.

Errata to codes and standards may be posted on the ASME Web site under the Committee Pages to provide corrections to incorrectly published items, or to correct typographical or grammatical errors in codes and standards. Such errata shall be used on the date posted.

The Committee Pages can be found at <http://cstools.asme.org/>. There is an option available to automatically receive an e-mail notification when errata are posted to a particular code or standard. This option can be found on the appropriate Committee Page after selecting "Errata" in the "Publication Information" section.

ASME is the registered trademark of The American Society of Mechanical Engineers.

This code or standard was developed under procedures accredited as meeting the criteria for American National Standards. The Standards Committee that approved the code or standard was balanced to assure that individuals from competent and concerned interests have had an opportunity to participate. The proposed code or standard was made available for public review and comment that provides an opportunity for additional public input from industry, academia, regulatory agencies, and the public-at-large.

ASME does not "approve," "rate," or "endorse" any item, construction, proprietary device, or activity.

ASME does not take any position with respect to the validity of any patent rights asserted in connection with any items mentioned in this document, and does not undertake to insure anyone utilizing a standard against liability for infringement of any applicable letters patent, nor assumes any such liability. Users of a code or standard are expressly advised that determination of the validity of any such patent rights, and the risk of infringement of such rights, is entirely their own responsibility.

Participation by federal agency representative(s) or person(s) affiliated with industry is not to be interpreted as government or industry endorsement of this code or standard.

ASME accepts responsibility for only those interpretations of this document issued in accordance with the established ASME procedures and policies, which precludes the issuance of interpretations by individuals.

No part of this document may be reproduced in any form,
in an electronic retrieval system or otherwise,
without the prior written permission of the publisher.

The American Society of Mechanical Engineers
Two Park Avenue, New York, NY 10016-5990

Copyright © 2016 by
THE AMERICAN SOCIETY OF MECHANICAL ENGINEERS
All rights reserved
Printed in U.S.A.

CONTENTS

Foreword	v	
Committee Roster	vii	
B30 Standard Introduction	ix	
Summary of Changes	xii	
Chapter 22-0	Scope, Definitions, Personnel Competence, Translations, and References	1
Section 22-0.1	Scope of B30.22	1
Section 22-0.2	Definitions	1
Section 22-0.3	Legend for Figs. 22-0.3-1 Through 22-0.3-4	9
Section 22-0.4	Nomenclature for Articulating Cranes	14
Section 22-0.5	Personnel Competence	14
Section 22-0.6	Translations of Safety-Related Information and Control Designations	14
Section 22-0.7	References	14
Chapter 22-1	Construction and Characteristics	16
Section 22-1.1	Load Ratings	16
Section 22-1.2	Boom Lift, Boom Telescoping, and Load Hoist Mechanisms	18
Section 22-1.3	Swing Mechanism	19
Section 22-1.4	Crane Transport	19
Section 22-1.5	Ropes and Reeving Accessories	19
Section 22-1.6	Controls	20
Section 22-1.7	Installation	21
Section 22-1.8	Construction	21
Section 22-1.9	Operating Manual	22
Chapter 22-2	Inspection, Testing, and Maintenance	23
Section 22-2.1	Inspection	23
Section 22-2.2	Testing	24
Section 22-2.3	Maintenance	25
Section 22-2.4	Rope Inspection, Replacement, and Maintenance	26
Chapter 22-3	Operation	28
Section 22-3.1	Qualifications and Responsibilities	28
Section 22-3.2	Operating Practices	33
Section 22-3.3	Signals	34
Section 22-3.4	Operating Near Electric Power Lines	35
Figures		
22-0.2.1-1	Commercial Truck-Mounted With Ground Control	2
22-0.2.1-2	Commercial Truck-Mounted With Top Seat Control	3
22-0.2.1-3	Commercial Truck-Rear-Mounted With Remote Control	4
22-0.2.1-4	Crawler-Mounted	4
22-0.2.1-5	Stationary Installation	5
22-0.2.1-6	Railcar Installation	5
22-0.2.1-7	Trailer-Mounted	5
22-0.2.1-8	Traveling Base-Mounted on Trailer	6
22-0.2.1-9	Off-Road Vehicle	6
22-0.3-1	Definitions of Specifications for Articulating Cranes	10
22-0.3-2	Hook Approach	13
22-0.3-3	Elevation Below Horizontal	13

22-0.3-4	Elevation Above Horizontal	13
22-0.4-1	Nomenclature for Articulating Cranes	15
22-1.1.3-1	Work Areas	17
22-2.4.2-1	Core Failure in 19 × 7 Rotation-Resistant Rope	27
22-3.3.4-1	Standard Hand Signals	34
22-3.4.1-1	Danger Zone for Cranes and Lifted Loads Operating Near Electrical Transmission Lines	36
Table		
22-3.4.2-1	Required Clearance for Normal Voltage in Operation Near High Voltage Power Lines and Operation in Transit With No Load and Boom or Mast Lowered	38

ASMENORMDOC.COM : Click to view the full PDF of ASME B30.22 2016

FOREWORD

This American National Standard, Safety Standard for Cableways, Cranes, Derricks, Hoists, Hooks, Jacks, and Slings, has been developed under the procedures accredited by the American National Standards Institute (ANSI). This Standard had its beginning in December 1916 when an eight-page Code of Safety Standards for Cranes, prepared by an ASME Committee on the Protection of Industrial Workers, was presented at the annual meeting of the ASME.

Meetings and discussions regarding safety on cranes, derricks, and hoists were held from 1920 to 1925, involving the ASME Safety Code Correlating Committee, the Association of Iron and Steel Electrical Engineers, the American Museum of Safety, the American Engineering Standards Committee (AESC) [later changed to American Standards Association (ASA), then to the United States of America Standards Institute (USASI), and finally to ANSI], Department of Labor — State of New Jersey, Department of Labor and Industry — State of Pennsylvania, and the Locomotive Crane Manufacturers Association. On June 11, 1925, AESC approved the ASME Safety Code Correlating Committee's recommendation and authorized the project with the U.S. Department of the Navy, Bureau of Yards and Docks, and ASME as sponsors.

In March 1926, invitations were issued to 50 organizations to appoint representatives to a Sectional Committee. The call for organization of this Sectional Committee was sent out October 2, 1926, and the committee organized November 4, 1926, with 57 members representing 29 national organizations. Commencing June 1, 1927, and using the eight-page code published by ASME in 1916 as a basis, the Sectional Committee developed the Safety Code for Cranes, Derricks, and Hoists. The early drafts of this safety code included requirements for jacks, but, due to inputs and comments on those drafts, the Sectional Committee decided in 1938 to make the requirements for jacks a separate code. In January 1943, ASA B30.2-1943 was published addressing a multitude of equipment types, and in August 1943, ASA B30.1-1943 was published just addressing jacks. Both documents were reaffirmed in 1952 and widely accepted as safety standards.

Due to changes in design, advancement in techniques, and general interest of labor and industry in safety, the Sectional Committee, under the joint sponsorship of ASME and the Bureau of Yards and Docks (now the Naval Facilities Engineering Command), was reorganized on January 31, 1962, with 39 members representing 27 national organizations. The new committee changed the format of ASA B30.2-1943 so that the multitude of equipment types it addressed could be published in separate volumes that could completely cover the construction, installation, inspection, testing, maintenance, and operation of each type of equipment that was included in the scope of ASA B30.2. This format change resulted in B30.3, B30.5, B30.6, B30.11, and B30.16 being initially published as revisions of B30.2, with the remainder of the B30 volumes being published as totally new volumes. ASA changed its name to USASI in 1966 and to ANSI in 1969, which resulted in B30 volumes from 1943 to 1968 being designated as either ASA B30, USAS B30, or ANSI B30, depending on their date of publication.

In 1982, the Committee was reorganized as an Accredited Organization Committee, operating under procedures developed by ASME and accredited by ANSI. This Standard presents a coordinated set of rules that may serve as a guide to government and other regulatory bodies and municipal authorities responsible for the guarding and inspection of the equipment falling within its scope. The suggestions leading to accident prevention are given both as mandatory and advisory provisions; compliance with both types may be required by employers of their employees.

In case of practical difficulties, new developments, or unnecessary hardship, the administrative or regulatory authority may grant variances from the literal requirements or permit the use of other devices or methods but only when it is clearly evident that an equivalent degree of protection is thereby secured. To secure uniform application and interpretation of this Standard, administrative or regulatory authorities are urged to consult the B30 Committee, in accordance with the format described in Section IX of the Introduction, before rendering decisions on disputed points.

Safety codes and standards are intended to enhance public safety. Revisions result from committee consideration of factors such as technological advances, new data, and changing environmental and industry needs. Revisions do not imply that previous editions were inadequate.

The first edition of B30.22 was issued in 1987, and new editions were published in 1993, 2000, 2005, and 2010. The 2010 edition incorporated the addition of responsibilities, hand signals, and more comprehensive information on operation near electric power lines.

This 2016 edition contains revisions to all chapters. The most notable changes include installation requirements, clarification of testing, lift director responsibilities, and setup and operating practices.

This Volume, which was approved by the B30 Committee and by ASME, was approved by ANSI and designated as an American National Standard on April 27, 2016.

ASMENORMDOC.COM : Click to view the full PDF of ASME B30.22 2016

ASME B30 COMMITTEE

Safety Standard for Cableways, Cranes, Derricks, Hoists, Hooks, Jacks, and Slings

(The following is the roster of the Committee at the time of approval of this Standard.)

STANDARDS COMMITTEE OFFICERS

B. D. Closson, *Chair*
T. L. Blanton, *Vice Chair*
K. M. Hyam, *Secretary*

STANDARDS COMMITTEE PERSONNEL

N. E. Andrew, LTS Cranes Mechanical
M. Eggenberger, *Alternate*, Berry Contracting, Inc.
G. Austin, Terex Corp.
T. L. Blanton, NACB Group, Inc.
R. Ohman, *Alternate*, Verde Concepts, Inc.
P. A. Boeckman, The Crosby Group
C. E. Lucas, *Alternate*, The Crosby Group
P. W. Boyd, The Boeing Co.
M. E. Brunet, The Manitowoc Co.
A. L. Calta, *Alternate*, The Manitowoc Co.
B. D. Closson, Craft Forensic Services
B. A. Pickett, *Alternate*, Systems Engineering and Forensic Services
J. A. Danielson, The Boeing Co.
D. Decker, Becket, LLC
L. D. DeMark, Equipment Training Solutions, LLC
D. F. Jordan, *Alternate*, BP America
D. W. Eckstine, Eckstine & Associates
G. J. Brent, *Alternate*, NCCCO
R. J. Edwards, NBIS Claims and Risk Management, Inc.
A. J. Egging, National Oilwell Varco
R. Stanoch, *Alternate*, National Oilwell Varco
E. D. Fidler, The Manitowoc Co.
G. D. Miller, *Alternate*, The Manitowoc Co.
J. A. Gilbert, Associated Wire Rope Fabricators
J. L. Gordon, Associated Chain and Lifting Products
N. C. Hargreaves, Hargreaves Consulting, LLC
G. B. Hetherston, E. I. DuPont
R. J. Bolen, *Alternate*, E. I. DuPont
K. M. Hyam, The American Society of Mechanical Engineers
M. M. Jaxtheimer, Navy Crane Center
S. R. Gridley, *Alternate*, Navy Crane Center
P. R. Juhren, Morrow Equipment Co., LLC
M. J. Quinn, *Alternate*, Morrow Equipment Co., LLC
R. M. Kohner, Landmark Engineering Services, Ltd.
D. Duerr, *Alternate*, 2DM Associates, Inc.
A. J. Lusi, Jr., Lumark Consulting, LLP
K. J. Shinn, *Alternate*, K. J. Shinn, Inc.

E. K. Marburg, Columbus McKinnon Corp.
J. R. Burkey, *Alternate*, Columbus McKinnon Corp.
L. D. Means, Means Engineering and Consulting
D. A. Henninger, *Alternate*, Bridon American
M. W. Mills, Liberty Mutual Insurance
D. M. Gordon, *Alternate*, Liberty Mutual Insurance
D. L. Morgan, Critical Lift Consultants, LLC
T. C. Mackey, *Alternate*, WRPS Hanford
W. E. Osborn, Ingersoll Rand
S. D. Wood, *Alternate*, Link-Belt Construction Equipment Co.
R. M. Parnell, Industrial Training International
W. C. Dickinson, Jr., *Alternate*, Industrial Training International
J. T. Perkins, Solarex
J. R. Schober, *Alternate*, American Bridge Co.
J. E. Richardson, Navy Crane Center
K. Kennedy, *Alternate*, Navy Crane Center
D. W. Ritchie, David Ritchie Consultant, LLC
L. K. Shapiro, *Alternate*, Howard I. Shapiro & Associates
J. W. Rowland III, Consultant
D. A. Moore, *Alternate*, Unified Engineering
J. C. Ryan, Boh Bros. Construction Co., LLC
A. R. Ruud, *Alternate*, Atkinson Construction
D. W. Smith, STI Group
S. K. Rammelsberg, *Alternate*, Chicago Bridge & Iron Co.
W. J. Smith, Jr., NBIS Claims and Risk Management, Inc.
J. Schoppert, *Alternate*, NBIS Claims and Risk Management, Inc.
R. S. Stemp, Lampson International, LLC
E. P. Vliet, *Alternate*, Turner Industries Group
R. G. Strain, Advanced Crane Technologies, LLC
J. Sturm, Sturm Corp.
P. D. Sweeney, General Dynamics Electric Boat
B. M. Casey, *Alternate*, General Dynamics Electric Boat
J. D. Wiethorn, Haag Engineering Co.
M. Gardiner, *Alternate*, Haag Engineering Co.
R. C. Wild, CJ Drilling, Inc.
J. Dudley, *Alternate*, Archer Western Contractors
D. N. Wolff, National Crane/Manitowoc Crane Group
J. A. Pilgrim, *Alternate*, Manitowoc Crane Group

HONORARY MEMBERS

J. W. Downs, Jr., Downs Crane and Hoist Co.
J. L. Franks, Consultant
C. W. Ireland, National Oilwell Varco
J. M. Klibert, Lift-All Co., Inc.
R. W. Parry, Consultant
P. S. Zorich, Consultant

B30.22 SUBCOMMITTEE PERSONNEL

M. M. Jaxtheimer, *Chair*, Navy Crane Center
T. D. Arkilander, Cargotec USA, Inc.
G. Austin, Terex Corp.
A. L. Calta, The Manitowoc Co.
A. J. Lusi, Jr., Lumark Consulting, LLP
J. Parnell, Consultant

K. Reynolds, Consultant
M. Schroeder, Stellar Industries
W. Timm, Palfinger North America
P. A. Vallejos, Mission Support Alliance
D. N. Wolff, National Crane/Manitowoc Crane Group
J. A. Pilgrim, *Alternate*, Manitowoc Cranes

B30 INTEREST REVIEW GROUP

O. Akinboboye, Ropetech Engineering Services
J. D. Cannon, Consultant
M. Eggenberger, Berry Contracting, Inc.
A. Gomes Rocha, Belgo Bekaert Arames
H. A. Hashem, Saudi Aramco
J. Hui, School of Civil Engineering, People's Republic of China

A. C. Mattoli, Prowinch, LLC
M. W. Osborne, E-Crane International USA
G. L. Owens, Consultant
W. Rumburg, Crane Consultants, Inc.
C.-C. Tsaur, Institute of Occupational Safety and Health, Taiwan

B30 REGULATORY AUTHORITY COUNCIL

C. Shelhamer, *Chair*, New York City Department of Buildings
A. O. Omran, *Alternate*, New York City Department of Buildings
K. M. Hyam, *Secretary*, The American Society of Mechanical Engineers
G. Beer, Iowa OSHA
L. G. Champion, U.S. Department of Labor/OSHA
W. L. Cooper, Arizona Division of Occupational Safety and Health
R. Feidt, Stephenson Equipment, Inc.

C. Harris, City of Chicago, Department of Buildings
J. L. Lankford, State of Nevada/OSHA
A. Lundeen, State of Washington, Department of Labor and Industries
G. E. Pushies, MIOSHA
C. N. Stribling, Jr., Kentucky Labor Cabinet
T. Taylor, State of Minnesota, Department of Labor and Industry
C. Tolson, State of California, OSH Standards Board

SAFETY STANDARD FOR CABLEWAYS, CRANES, DERRICKS, HOISTS, HOOKS, JACKS, AND SLINGS

B30 STANDARD INTRODUCTION

(16)

SECTION I: SCOPE

The ASME B30 Standard contains provisions that apply to the construction, installation, operation, inspection, testing, maintenance, and use of cranes and other lifting and material-movement related equipment. For the convenience of the reader, the Standard has been divided into separate volumes. Each volume has been written under the direction of the ASME B30 Standard Committee and has successfully completed a consensus approval process under the general auspices of the American National Standards Institute (ANSI).

As of the date of issuance of this Volume, the B30 Standard comprises the following volumes:

- | | | | |
|--------|---|--------|-----------------------------|
| B30.1 | Jacks, Industrial Rollers, Air Casters, and Hydraulic Gantries | B30.23 | Personnel Lifting Systems |
| B30.2 | Overhead and Gantry Cranes (Top Running Bridge, Single or Multiple Girder, Top Running Trolley Hoist) | B30.24 | Container Cranes |
| B30.3 | Tower Cranes | B30.25 | Scrap and Material Handlers |
| B30.4 | Portal and Pedestal Cranes | B30.26 | Rigging Hardware |
| B30.5 | Mobile and Locomotive Cranes | B30.27 | Material Placement Systems |
| B30.6 | Derricks | B30.28 | Balance Lifting Units |
| B30.7 | Winches | B30.29 | Self-Erecting Tower Cranes |
| B30.8 | Floating Cranes and Floating Derricks | B30.30 | Ropes ¹ |
| B30.9 | Slings | | |
| B30.10 | Hooks | | |
| B30.11 | Monorails and Underhung Cranes | | |
| B30.12 | Handling Loads Suspended From Rotorcraft | | |
| B30.13 | Storage/Retrieval (S/R) Machines and Associated Equipment | | |
| B30.14 | Side Boom Tractors | | |
| B30.15 | Mobile Hydraulic Cranes
(withdrawn 1982 — requirements found in latest revision of B30.5) | | |
| B30.16 | Overhead Hoists (Underhung) | | |
| B30.17 | Overhead and Gantry Cranes (Top Running Bridge, Single Girder, Underhung Hoist) | | |
| B30.18 | Stacker Cranes (Top or Under Running Bridge, Multiple Girder With Top or Under Running Trolley Hoist) | | |
| B30.19 | Cableways | | |
| B30.20 | Below-the-Hook Lifting Devices | | |
| B30.21 | Lever Hoists | | |
| B30.22 | Articulating Boom Cranes | | |

SECTION II: SCOPE EXCLUSIONS

Any exclusion of, or limitations applicable to, the equipment, requirements, recommendations, or operations contained in this Standard are established in the affected volume's scope.

SECTION III: PURPOSE

The B30 Standard is intended to

- (a) prevent or minimize injury to workers, and otherwise provide for the protection of life, limb, and property by prescribing safety requirements
- (b) provide direction to manufacturers, owners, employers, users, and others concerned with, or responsible for, its application
- (c) guide governments and other regulatory bodies in the development, promulgation, and enforcement of appropriate safety directives

SECTION IV: USE BY REGULATORY AGENCIES

These volumes may be adopted in whole or in part for governmental or regulatory use. If adopted for governmental use, the references to other national codes and standards in the specific volumes may be changed to refer to the corresponding regulations of the governmental authorities.

SECTION V: EFFECTIVE DATE

(a) *Effective Date.* The effective date of this Volume of the B30 Standard shall be 1 yr after its date of issuance.

¹ This volume is currently in the development process.

Construction, installation, inspection, testing, maintenance, and operation of equipment manufactured and facilities constructed after the effective date of this Volume shall conform to the mandatory requirements of this Volume.

(b) *Existing Installations.* Equipment manufactured and facilities constructed prior to the effective date of this Volume of the B30 Standard shall be subject to the inspection, testing, maintenance, and operation requirements of this Standard after the effective date.

It is not the intent of this Volume of the B30 Standard to require retrofitting of existing equipment. However, when an item is being modified, its performance requirements shall be reviewed relative to the requirements within the current volume. The need to meet the current requirements shall be evaluated by a qualified person selected by the owner (user). Recommended changes shall be made by the owner (user) within 1 yr.

SECTION VI: REQUIREMENTS AND RECOMMENDATIONS

Requirements of this Standard are characterized by use of the word *shall*. Recommendations of this Standard are characterized by the word *should*.

SECTION VII: USE OF MEASUREMENT UNITS

This Standard contains SI (metric) units as well as U.S. Customary units. The values stated in U.S. Customary units are to be regarded as the standard. The SI units are a direct (soft) conversion from the U.S. Customary units.

SECTION VIII: REQUESTS FOR REVISION

The B30 Standard Committee will consider requests for revision of any of the volumes within the B30 Standard. Such requests should be directed to

Secretary, B30 Standard Committee
ASME Codes and Standards
Two Park Avenue
New York, NY 10016-5990

Requests should be in the following format:

Volume: Cite the designation and title of the volume.
Edition: Cite the applicable edition of the volume.
Subject: Cite the applicable paragraph number(s) and the relevant heading(s).
Request: Indicate the suggested revision.
Rationale: State the rationale for the suggested revision.

Upon receipt by the Secretary, the request will be forwarded to the relevant B30 Subcommittee for consideration and action. Correspondence will be provided to

the requester defining the actions undertaken by the B30 Standard Committee.

SECTION IX: REQUESTS FOR INTERPRETATION

The B30 Standard Committee will render an interpretation of the provisions of the B30 Standard. Such requests should be directed to

Secretary, B30 Standard Committee
ASME Codes and Standards
Two Park Avenue
New York, NY 10016-5990

Requests should be in the following format:

Volume: Cite the designation and title of the volume.
Edition: Cite the applicable edition of the volume.
Subject: Cite the applicable paragraph number(s) and the relevant heading(s).
Question: Phrase the question as a request for an interpretation of a specific provision suitable for general understanding and use, not as a request for approval of a proprietary design or situation. Plans or drawings that explain the question may be submitted to clarify the question. However, they should not contain any proprietary names or information.

Upon receipt by the Secretary, the request will be forwarded to the relevant B30 Subcommittee for a draft response, which will then be subject to approval by the B30 Standard Committee prior to its formal issuance.

Interpretations to the B30 Standard will be published in the subsequent edition of the respective volume, and will be available online at <http://cstools.asme.org/>.

SECTION X: ADDITIONAL GUIDANCE

The equipment covered by the B30 Standard is subject to hazards that cannot be abated by mechanical means, but only by the exercise of intelligence, care, and common sense. It is therefore essential to have personnel involved in the use and operation of equipment who are competent, careful, physically and mentally qualified, and trained in the proper operation of the equipment and the handling of loads. Serious hazards include, but are not limited to, improper or inadequate maintenance, overloading, dropping or slipping of the load, obstructing the free passage of the load, and using equipment for a purpose for which it was not intended or designed.

The B30 Standard Committee fully realizes the importance of proper design factors, minimum or maximum dimensions, and other limiting criteria of wire rope or chain and their fastenings, sheaves, sprockets, drums, and similar equipment covered by the standard, all of

which are closely connected with safety. Sizes, strengths, and similar criteria are dependent on many different factors, often varying with the installation and uses. These factors depend on

- (a) the condition of the equipment or material
- (b) the loads
- (c) the acceleration or speed of the ropes, chains, sheaves, sprockets, or drums
- (d) the type of attachments

(e) the number, size, and arrangement of sheaves or other parts

(f) environmental conditions causing corrosion or wear

(g) many variables that must be considered in each individual case

The requirements and recommendations provided in the volumes must be interpreted accordingly, and judgment used in determining their application.

ASMENORMDOC.COM : Click to view the full PDF of ASME B30.22 2016

ASME B30.22-2016

SUMMARY OF CHANGES

Following approval by the ASME B30 Committee and ASME, and after public review, ASME B30.22-2016 was approved by the American National Standards Institute on April 27, 2016.

In ASME B30.22-2016, figures and tables have been redesignated. ASME B30.22-2016 also includes editorial changes, revisions, and corrections, which are identified by a margin note, **(16)**.

<i>Page</i>	<i>Location</i>	<i>Change</i>
ix–xi	B30 Standard Introduction	Updated
1–7	Chapter 22-0	Chapter title revised
	Section 22-0.1	(1) First and second paragraphs revised (2) Subparagraphs (a) through (e) revised
	22-0.2.1	(1) Title revised (2) Definitions of <i>wheel-mounted</i> and <i>crawler-mounted</i> revised
	22-0.2.2	(1) Definition of <i>alterations (modification)</i> and <i>vehicle</i> added (2) Definitions of <i>appointed, authorized, carrier, and designated person</i> deleted (3) Definitions of <i>operational aid, shall, and should</i> revised
	Fig. 22-0.2.1-5	Revised
	Fig. 22-0.2.1-6	Revised
	Fig. 22-0.2.1-7	Revised
	Fig. 22-0.2.1-8	Revised
	Fig. 22-0.2.1-9	(1) Deleted and Fig. 22-0.2.1-11 renumbered as Fig. 22-0.2.1-4 (2) Fig. 22-0.2.1-10 deleted
14	Section 22-0.5	Added, old Section 22-0.5 redesignated as Section 22-0.7 and revised
	Section 22-0.6	Added
15	Fig. 22-0.4-1	Revised
16–18	22-1.1.1	Subparagraph (a) in-text table revised
	22-1.1.2	Revised in its entirety
	22-1.1.3	Subparagraph (a)(4) revised
19	22-1.2.3	(1) Subparagraph (b)(2)(-a) revised (2) In subpara. (c), Note added, and subpara. (d) added

<i>Page</i>	<i>Location</i>	<i>Change</i>	
20	22-1.5.1	Subparagraph (c) revised	
	22-1.5.2	Subparagraph (d) revised	
	22-1.5.3	Subparagraphs (b) and (d) revised	
	22-1.5.5	(1) Subparagraph (a) revised (2) Note added	
	22-1.6.1	(1) Subparagraph (c) revised (2) Subparagraph (d) deleted	
21	Section 22-1.7	Revised in its entirety	
	22-1.8.2.2	Revised	
	22-1.8.3	Revised	
22	22-1.8.7	Revised in its entirety	
	22-1.8.7.1	Added	
	22-1.8.8	Added	
	Section 22-1.9	Revised	
23	22-2.1.1	General paragraph added, and subsequent paragraphs redesignated	
	22-2.1.2	Subparagraph (a) revised	
	22-2.1.3	First paragraph revised and subparagraph (l) added	
	22-2.1.4	First and second paragraphs revised	
	24, 25	22-2.1.5	Subparagraph (b) revised
26	22-2.1.6	(1) In newly redesignated para. 22-2.1.6, subparagraphs (a) and (b) revised (2) Old para. 22-2.1.6 deleted	
	Section 22-2.2	Revised	
	22-2.2.1	Subparagraph (a) revised	
	22-2.2.2	Revised in its entirety	
	22-2.2.3	Added	
	22-2.3.2	Subparagraph (c) revised	
	22-2.3.3	(1) Title and subparas. (a) and (d) revised (2) Subparagraph (e) redesignated as (g), and new subparas. (e) and (f) added	
	22-2.4.1	Revised	
	22-2.4.2	Subparagraphs (b)(2) and (b)(2)(-b) revised	
	28	22-3.1.1	Subparagraph (b) revised
	29–35	22-3.1.3	Definition for <i>lift director</i> added
22-3.1.3.1.1		Subparagraph (e) revised	
22-3.1.3.1.2		Subparagraphs (f), (h), (k), and (l) revised	

<i>Page</i>	<i>Location</i>	<i>Change</i>
	22-3.1.3.2	(1) Title revised (2) Paragraph added
	22-3.1.3.2.1	New paragraph designator added above old 22-3.1.3.2(a)
	22-3.1.3.2.2	Added
	Fig. 22-3.1.3.1.2-1	Renumbered as Fig. 22-3.3.4-1
	22-3.1.3.3.1	Revised in its entirety
	22-3.1.3.3.2	Revised in its entirety
	22-3.2.1	(1) Title revised (2) Subparagraphs (b) and (c) revised
	22-3.2.2	(1) Subparagraph (b)(2) revised (2) Subparagraph (b)(5) added
	22-3.2.3	New 22-3.2.3 added, old paragraph redesignated as 22-3.2.4
	22-3.2.4	Redesignated as 22-3.2.5 and revised in its entirety
	22-3.2.5	Redesignated as 22-3.2.6 and revised in its entirety
	22-3.2.7	Added
	22-3.2.8	Added
	Section 22-3.3	(1) Revised in its entirety, and subsequent paragraphs and references renumbered accordingly (2) Paragraphs 22-3.3.2 through 22-3.3.2.5 redesignated as Section 22-3.4 through para. 22-3.4.5 and references renumbered accordingly
36-38	Fig. 22-3.3.2.1-1	Renumbered as Fig. 22-3.4.1-1 and revised
	Table 22-3.3.2.2-1	Renumbered as Table 22-3.4.2-1

ARTICULATING BOOM CRANES

Chapter 22-0

Scope, Definitions, Personnel Competence, Translations, and References

(16)

(16) SECTION 22-0.1: SCOPE OF B30.22

The scope includes cranes of the types described in para. 22-0.2.1 that are articulated by hydraulic cylinders and powered by internal combustion engines or electric motors and that are mounted on a mobile chassis or stationary installation. Articulating cranes equipped with a load hoist mechanism to broaden their versatility are covered by this Volume.

Some basic machine types within this scope are convertible for excavating work and other uses not considered to be lifting service. The requirements of this Volume are applicable only to such machines when used as lifting cranes. When cranes within the scope of this Volume are used for service other than lifting service, the manufacturer or (when not available from the manufacturer) a qualified person shall establish the ratings, operating limitations, maintenance, testing, and inspection requirements that apply during that use.

Exemptions from this Volume include

- (a) units with a maximum rated capacity of 2,000 lb (907 kg) or less
- (b) units with booms constructed of nonconductive-type materials
- (c) units equipped with or designed primarily for personnel baskets, platforms, ladders, etc.
- (d) units when equipped with nonlifting attachments
- (e) units while used in forestry and logging applications
- (f) telescoping boom cranes that do not articulate (covered under ASME B30.5)
- (g) scrap and material handlers as defined in ASME B30.25

SECTION 22-0.2: DEFINITIONS

(16) 22-0.2.1 Mounting of Articulating Boom Cranes

commercial truck-mounted: a crane, consisting of a rotating mast, mainframe or base, boom, and one or more operator's stations, such as ground controls (Fig. 22-0.2.1-1), top seat controls (Fig. 22-0.2.1-2), or remote controls

(Fig. 22-0.2.1-3), mounted on a frame attached to a commercial truck chassis, with or without a payload capability, whose power source may power the crane. The function is to lift, lower, and swing loads at various radii.

crawler-mounted: a crane, consisting of a rotating mast, mainframe or base, operator's station(s), and boom, mounted on crawler treads for travel. It may be equipped with a single control station or have separate stations for driving and operating. Its function is to lift, lower, and swing loads at various radii. See Fig. 22-0.2.1-4.

stationary: a crane, consisting of a rotating mast, mainframe or base, and boom, mounted on a stationary structure. The function is to lift, lower, and swing loads at various radii from a fixed center of rotation. See Fig. 22-0.2.1-5.

trailer- or railcar-mounted: a crane, consisting of a rotating mast, mainframe or base, and boom, mounted on a trailer or railcar. The function is to lift, lower, and swing loads at various radii. See Figs. 22-0.2.1-6 and 22-0.2.1-7.

traveling base-mounted: a crane, consisting of a rotating mast, boom, mainframe or base, and one or more operator's stations, mounted on a traveling base. The function is to lift, lower, and swing loads at various radii. See Fig. 22-0.2.1-8.

wheel-mounted: a crane, consisting of a rotating mast, mainframe or base, operator's station(s), and boom, mounted on commercial truck vehicle, a trailer, or an off-road vehicle equipped with axles and rubber-tired wheels. It may be equipped with a single control station or have separate stations for driving and operating. Its function is to lift, lower, and swing loads at various radii. See Figs. 22-0.2.1-1, 22-0.2.1-2, 22-0.2.1-3, 22-0.2.1-7, 22-0.2.1-8, and 22-0.2.1-9.

22-0.2.2 General Definitions

(16)

accessory: a secondary part or assembly of parts that contributes to the overall function and usefulness of a crane.

Fig. 22-0.2.1-1 Commercial Truck-Mounted With Ground Control

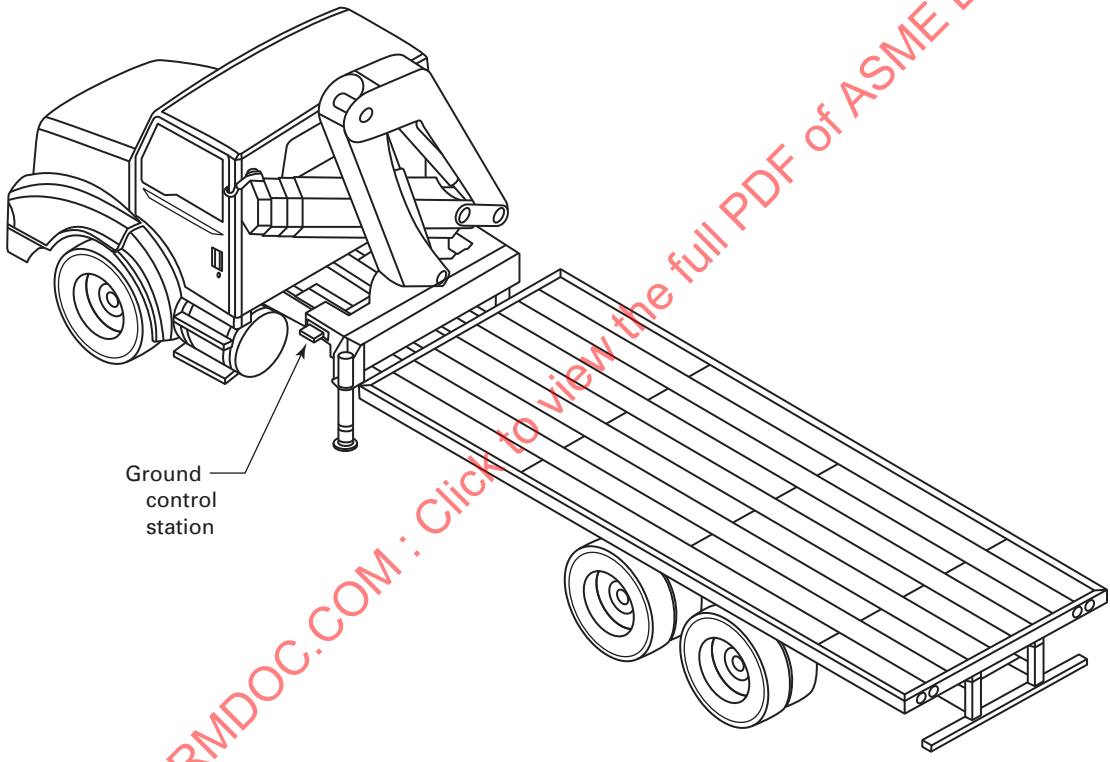

Fig. 22-0.2.1-2 Commercial Truck-Mounted With Top Seat Control

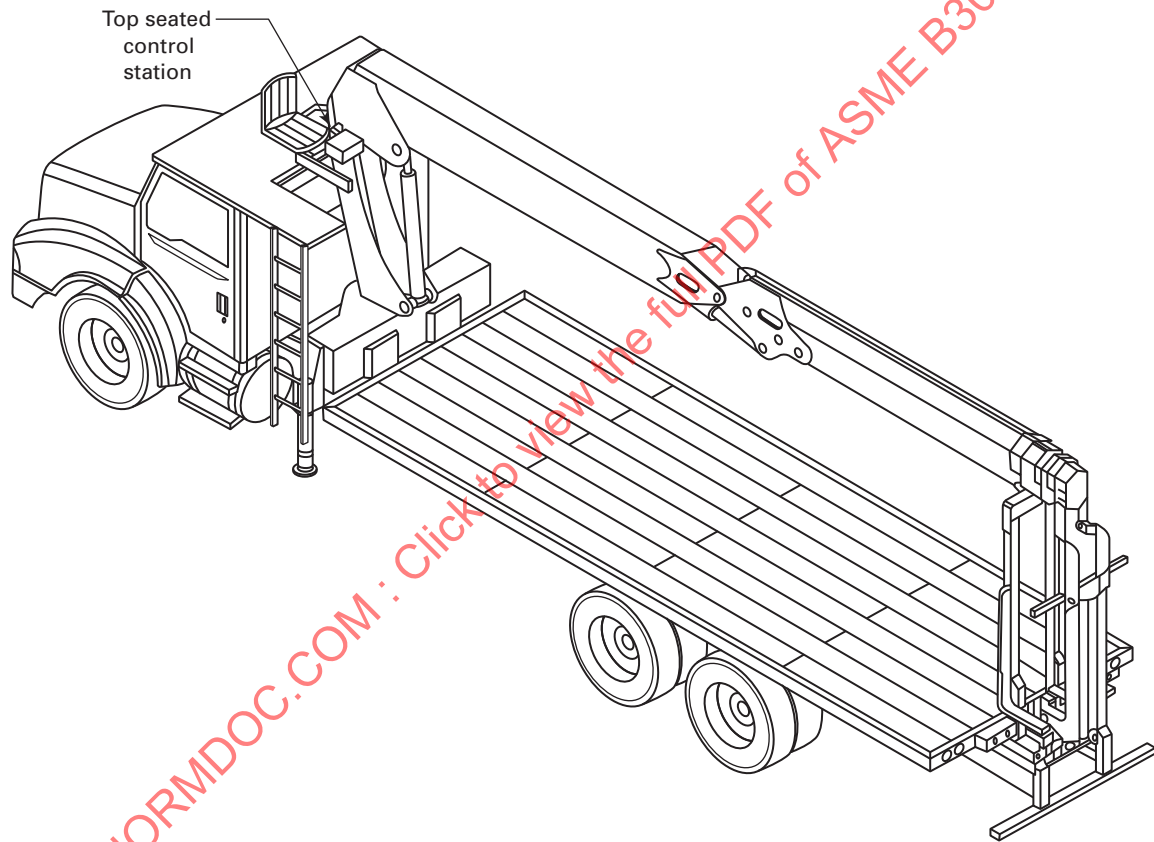
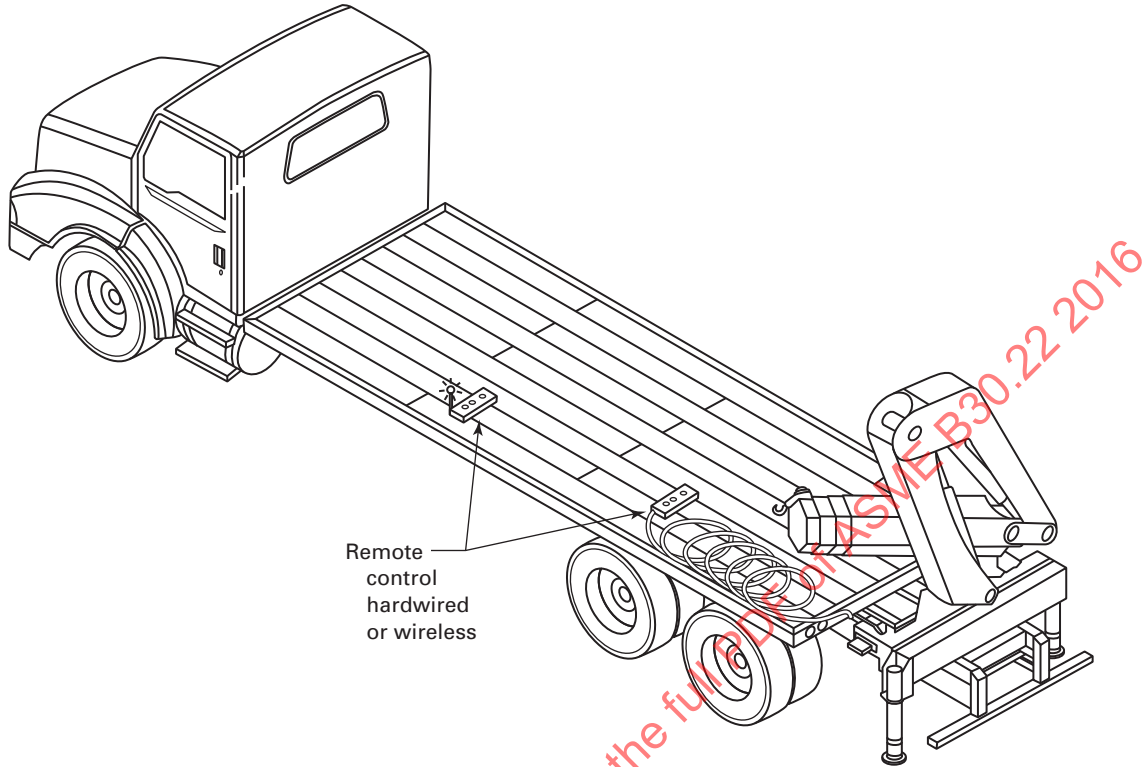

Fig. 22-0.2.1-3 Commercial Truck-Rear-Mounted With Remote Control



(16)

Fig. 22-0.2.1-4 Crawler-Mounted

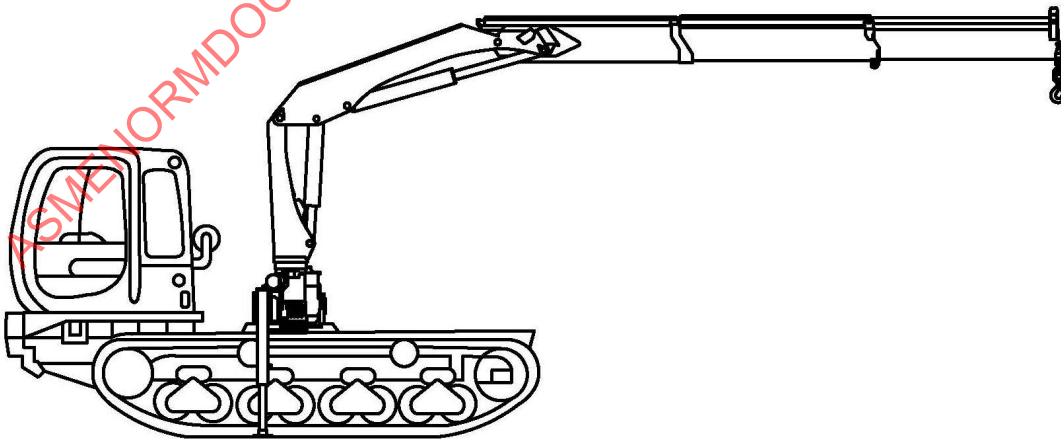

Fig. 22-0.2.1-5 Stationary Installation

(16)

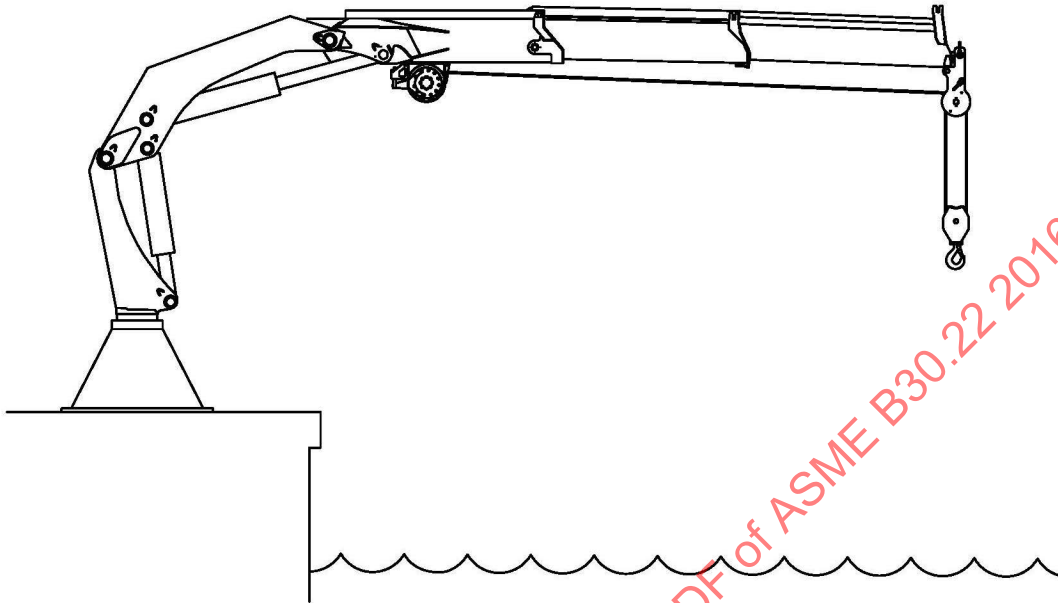

Fig. 22-0.2.1-6 Railcar Installation

(16)

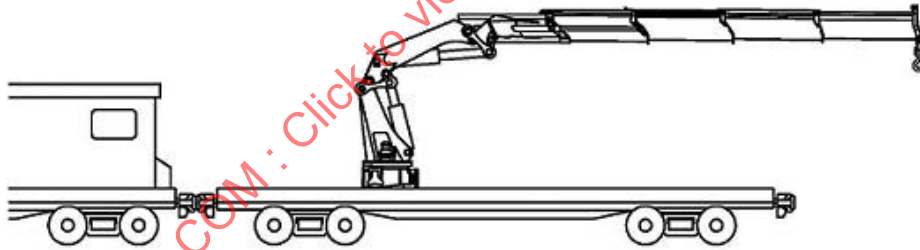
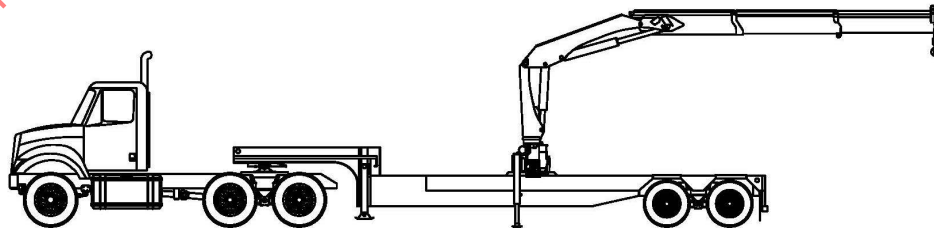

Fig. 22-0.2.1-7 Trailer-Mounted

(16)



(16)

Fig. 22-0.2.1-8 Traveling Base-Mounted on Trailer

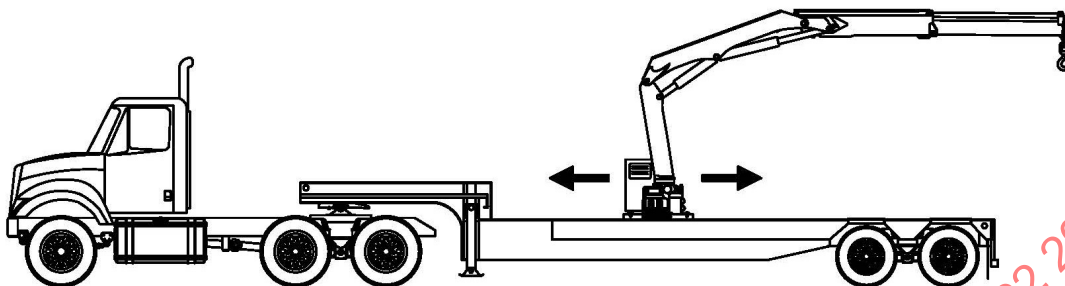

(16)

Fig. 22-0.2.1-9 Off-Road Vehicle

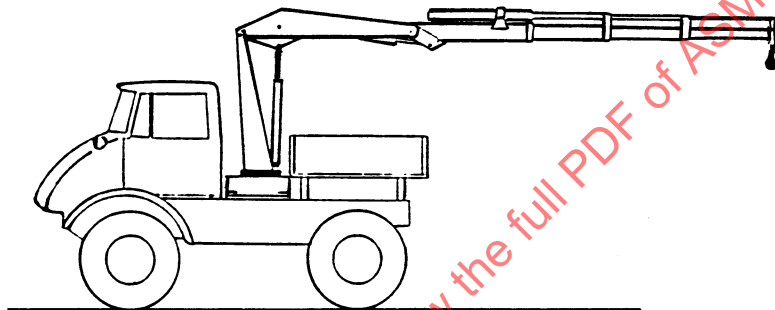

administrative or regulatory authority: governmental agency or the employer in the absence of governmental jurisdiction.

alteration (modification): any change in the original equipment manufacturer's design configuration of the crane that pertains to load-supporting components, load-positioning components, and other components that affect the safe load-carrying capability of the crane (e.g., counterweights, holding valves) including operational aids, limit devices, and load charts.

anti-two-block device: a device that, when activated, disengages all crane functions whose movement can cause two-blocking.

axle: the shaft or spindle with which or about which a wheel rotates. On wheel-mounted cranes, it refers to a type of axle assembly, including housings, gearing, differential, bearings, and mounting appurtenances.

axle (tandem): two or more axles mounted in tandem in a frame so as to divide the load between the axles and permit vertical oscillation of the wheels.

ballast (counterweight): weight used to supplement the weight of the machine in providing stability for lifting working loads.

boom extension cylinder: the hydraulic cylinder(s) that extends the boom's extensions.

boom extensions, manual or hydraulic (one or more): structural members, which extend and are usually located in or on the outer boom or on the jib boom.

brake: a device used for retarding or stopping motion.

cab: a housing that covers machine operator's or driver's station.

commercial truck vehicle: a commercial motor vehicle designed primarily for the transportation of property in connection with business and industry.

controls: a means for controlling the movement functions of the crane.

cab, station, or top seat: a control station directly attached to the crane where the operator sits or stands on the crane.

ground or floor: a control station directly attached to the crane, but where the operator stands on the ground — not the crane.

remote: a fixed or moveable control station not directly attached to the crane. This could be electrical (wired or wireless) or hydraulic controls.

crane: articulating boom crane.

crane rating: the crane shall be rated in ft-lb (N·m). This rating shall be established by multiplying the manufacturer's rated load by the minimum boom radius with the boom in its horizontal retracted position (all extension

booms retracted), outer and jib boom fully extended and hook pin height equal to the inner boom pin height.

crossover points: in multiple layer spooling of rope on drum, those points of rope contact where the rope crosses preceding rope layer.

drum: the cylindrical member around which a rope is wound for lifting and lowering the load.

dynamic loads: loads introduced into the machine or its components due to accelerating or decelerating forces.

electrically insulated: a material property that is related to the material's ability to resist conduction of electricity.

flange point: a point of contact between rope and drum flange where the rope changes layers.

inner boom: the structural member, attached to the mast, which supports the outer boom(s).

inner boom lift cylinder: the hydraulic cylinder that lifts the inner boom.

inner boom pivot: the horizontal pin about which the inner boom is raised or lowered relative to the mast.

jib (fly jib): an articulating or fixed boom assembly with or without extendable boom sections that attaches to the outer boom.

load, working: the external load in pounds (kilograms) applied to the crane, including the weight of load-attaching equipment such as slings, pallet forks, and grapples.

load block, lower: the assembly of hook or shackle, swivel, sheaves, pins, and frame suspended by the hoisting rope.

load block, upper: the assembly of shackle, swivel, sheaves, pins, and frame suspended from the boom point.

load hoist mechanism: a hoist drum or rope reeving system used for lifting and lowering loads.

load hook: a structural component that pins to the outer boom, jib boom, extensions, or the load line and is used for attaching loads to the crane.

load indicator: a device that measures the weight of the load.

load radius: the horizontal distance from the centerline of rotation to the centerline of the hook pin at any boom position.

load ratings: ratings in pounds (kilograms) established by the manufacturer.

mainframe (base): the stationary base of the crane that supports the mast or turntable.

mast: a frame for use in connection with supporting a boom from mainframe or base.

minimum breaking force: the minimum load at which a new and unused wire rope will break when loaded to destruction in direct tension.

model designation: manufacturer's model number for articulating boom crane.

mounting or suspension beam: a structural member used in three-point mounting concept, which allows the chassis frame to twist and transfers the crane's loading into chassis rails.

mounting structure: the structure on which the crane is mounted.

nonlifting attachment: devices attached to the crane that perform functions other than lifting a load, such as augers, tampers, and hydraulic hammers.

operational aid: an accessory that provides information to facilitate operation of a crane or that takes control of particular functions without action of the operator when a limiting condition is sensed. Examples of such devices include, but are not limited to, the following:

- (a) two-block damage prevention system
- (b) rated capacity indicator
- (c) rated capacity (load) limiter
- (d) crane level indicator
- (e) load indicator
- (f) minimum wrap limiter

outer boom: the structural member, attached to the inner boom, which supports the jib boom.

outer boom cylinder: the hydraulic cylinder that lifts and lowers the outer boom in relation to the inner boom.

outer boom pivot: the horizontal pin about which the outer boom is raised and lowered relative to the inner boom.

overload protection system: a system that automatically monitors the crane's lifting condition and prevents movement of the crane that results in an overload condition.

payload: the load or loads being transported by the commercial truck chassis from place to place.

qualified person: a person who, by possession of a recognized degree in an applicable field or a certificate of professional standing, or by extensive knowledge, training, and experience, has successfully demonstrated the ability to solve or resolve problems relating to the subject matter and work.

rated capacity indicator: a device that automatically monitors radius, load weight, and load rating and warns the crane operator of an overload condition.

rated capacity (load) limiter: a device that automatically monitors radius, load weight, and load rating and prevents movements of the crane, which would result in an overload condition.

reeving: a rope system in which the rope travels around drums and sheaves.

rope: refers to wire rope unless otherwise specified.

rotation resistant rope: a wire consisting of an inner layer of strands laid in one direction covered by a layer of

strands laid in the opposite direction; this has the effect of counteracting torque by reducing the tendency of the finished rope to rotate.

running rope: a rope that travels around sheaves or drums.

shall: a word indicating a requirement.

sheave: a grooved wheel or pulley over which the rope travels.

should: a word indicating a recommendation.

side loading: a load applied at an angle to the vertical plane of the boom.

stability: a condition in which the sum of the moments tending to overturn the unit is less than the sum of the moments resisting overturning.

stabilizer: an extendable or fixed member(s) attached to the mounting base to increase the stability of the crane, but which may not have the capability of relieving all of the weight from wheels or tracks.

stabilizer cylinder, horizontal: a hydraulic cylinder that extends the stabilizer.

stabilizer cylinder, vertical: a hydraulic cylinder that lowers the stabilizer pad to ground surface.

stabilizer pad: the structural member that distributes unit load over ground surface.

standard crane: as defined by the manufacturer.

structural competence: the ability of the machine and its components to withstand the stresses imposed by applied loads within the rating of the crane.

swing (slewing): rotation of the mast and boom for movement of loads in a horizontal direction about the axis of rotation.

swing (slewing) cylinders: two opposed single-acting cylinders that act on a rack gear which engages the mast pinion.

swing (slewing) drive gearbox: a mechanism that drives the mast or turntable.

swing (slewing) mechanism: the machinery involved in providing rotation of the mast and boom.

swivel: a load carrying member to permit rotation under load in a plane perpendicular to the direction of the load.

swiveling: the rotation of the load attachment portion (hook or shackle) of a lower load block or hook assembly about its axis of suspension in relation to the load line(s).

telescoping boom: consists of a boom from which one or more boom sections are telescoped for additional length.

tipping: see *stability*.

transit: the moving or transporting of a crane from one job site to another.

travel: the function of the machine moving under its own power from one location to another.

two-block damage-prevention system: a system that will stall when two-blocking occurs without causing damage to the hoist rope or crane machinery components.

two-blocking: the condition when the lower load block or hook assembly comes in contact with the upper load block or boom point sheave assembly.

vehicle: a mobile chassis on which an articulating crane is mounted. May include, but is not limited to, a commercial truck, a crawler chassis, an off-road chassis, a railcar, or a trailer.

weight of crane: weight of manufacturer's standard articulating boom crane. List separately weights of optional items such as hydraulic pump, hydraulic oil, counterweight, ballast, accessories, and equipment added by installer.

wheelbase: the distance between centers of front and rear axles. For a multiple axle assembly, the axle center for wheelbase measurement is taken at the midpoint of the assembly.

winch (hoist): a power driven drum(s) capable of lifting and lowering loads.

SECTION 22-0.3: LEGEND FOR FIGS. 22-0.3-1 THROUGH 22-0.3-4

A	<i>articulating angle</i> — the angle through which the outer boom moves from full retraction to full extension of the outer boom lift cylinder [Fig. 22-0.3-2]
CA	<i>cab-to-axle dimension</i> — the distance from the back of the chassis cab to the centerline of the rear axle, or tandem axle assembly [Fig. 22-0.3-1, illustration (a)]
CG	<i>center of gravity of crane</i> [Fig. 22-0.3-1, illustration (a)]
CGH	<i>crane center of gravity, horizontal</i> — the horizontal distance from the centerline of rotation to the center of weight of the stowed crane in the travel position [Fig. 22-0.3-1, illustration (a)]
CGL	<i>crane center of gravity, longitudinal</i> — longitudinal center of gravity as measured from the centerline of rotation to the center of weight of the stowed crane in the travel position [Fig. 22-0.3-1, illustration (a)]
CGV	<i>crane center of gravity, vertical</i> — the vertical center of gravity as measured from the mounting surface of the mainframe or base to the center of weight of the stowed crane in the travel position [Fig. 22-0.3-1, illustration (a)]
CH	<i>crane height</i> — the overall height measurement from the mounting surface of the crane to the highest point on the crane when stowed for travel [Fig. 22-0.3-1, illustration (a)]
CLL	<i>centerline of rotation location, longitudinal</i> — the horizontal distance parallel to the longitudinal centerline of the chassis from the rear axle of the chassis to the centerline of rotation of the mast [Fig. 22-0.3-1, illustration (a)]
CLR	<i>centerline of rotation</i> — the vertical axis about which the mast rotates [Fig. 22-0.3-1, illustration (a)]
D	<i>depth of crane</i> — mounting space for crane less clearances [Fig. 22-0.3-1, illustration (c)]
E1	<i>elevation below horizontal</i> — the travel of the hook to maximum depression below horizontal (Fig. 22-0.3-3)
E2	<i>elevation above horizontal</i> — the travel of the hook to maximum elevation above horizontal (Fig. 22-0.3-4)
F	<i>chassis height</i> — the height of the top of the chassis frame rail above ground level [Fig. 22-0.3-1, illustration (a)]
FO	<i>front overhang</i> — the distance from the most forward part of the vehicle or crane ahead of the front axle to the centerline of the front axle [Fig. 22-0.3-1, illustration (a)]
GC	<i>ground clearance</i> — the distance from the lowest part of the crane to the ground [Fig. 22-0.3-1, illustration (a)]
GL	<i>ground level</i> — the surface (assumed to be flat and level) on which the vehicle is supported [Fig. 22-0.3-1, illustration (a)]
HA	<i>hook approach, horizontal (HA_H) and vertical (HA_V)</i> — the horizontal distance from the centerline of rotation to the centerline of the hook pin and the vertical distance from the crane mounting surface to the centerline of the hook pin when inner boom is at maximum elevation, outer boom is fully retracted, and all extension booms are fully retracted (Fig. 22-0.3-2)
HR	<i>hook height, maximum retracted</i> — the height above the mounting surface of the base of the unit of the centerline of the boom tip hook pin with all booms at maximum elevation and all extensions fully retracted [Fig. 22-0.3-1, illustration (b)]
H1	<i>hook height, maximum 1st extension</i> — the height above the mounting surface of the base of the unit of the centerline of the boom tip hook pin with all booms at maximum elevation and the 1st extension stage boom fully retracted [Fig. 22-0.3-1, illustration (b)]
H2	<i>hook height, maximum 2nd extension</i> — the height above the mounting surface of the base of the unit of the centerline of the boom tip hook pin with all booms at maximum elevation and the 1st and 2nd extension boom fully retracted [Fig. 22-0.3-1, illustration (b)]
H3	<i>hook height, maximum 3rd extension</i> [Fig. 22-0.3-1, illustration (b)]
H4	<i>hook height, maximum 4th extension</i> [Fig. 22-0.3-1, illustration (b)]
MO	<i>mast offset</i> — the amount of offset from the centerline of the longitudinal axis of the vehicle to the centerline of rotation of the mast of the crane [Fig. 22-0.3-1, illustration (c)]
P	<i>stabilizer vertical travel</i> — the distance measured below mounting surface of crane to which the stabilizers could reach when fully extended [Fig. 22-0.3-1, illustration (b)]
R	<i>load radius</i> — the horizontal distance from the centerline of rotation to the centerline of the hook pin at any boom position [Fig. 22-0.3-1, illustration (b)]
RO	<i>rear overhang</i> — the distance from the most rearward part of the vehicle or crane behind the rear axle to the centerline of the rear axle in the traveling position [Fig. 22-0.3-1, illustration (a)]
RR	<i>horizontal reach, retracted</i> — the distance from the centerline of rotation to the centerline of the boom tip hook pin with all booms horizontal and all extensions fully retracted [Fig. 22-0.3-1, illustration (b)]
R1	<i>horizontal reach, 1st extension</i> — the distance from the centerline of rotation to the centerline of the boom tip hook pin with all booms horizontal and 1st extension stage fully extended [Fig. 22-0.3-1, illustration (b)]
R2	<i>horizontal reach, 2nd extension</i> [Fig. 22-0.3-1, illustration (b)]
R3	<i>horizontal reach, 3rd extension</i> [Fig. 22-0.3-1, illustration (b)]
R4	<i>horizontal reach, 4th extension</i> [Fig. 22-0.3-1, illustration (b)]
S	<i>stabilizer spread</i> — the distance measured between the centerlines of pivotal points of stabilizer pads at ground level at maximum spread [Fig. 22-0.3-1, illustration (b)]
W	<i>width of unit in stowed position</i> [Fig. 22-0.3-1, illustration (a)]
WB	<i>wheelbase</i> [Fig. 22-0.3-1, illustration (a)]

Fig. 22-0.3-1 Definitions of Specifications for Articulating Cranes

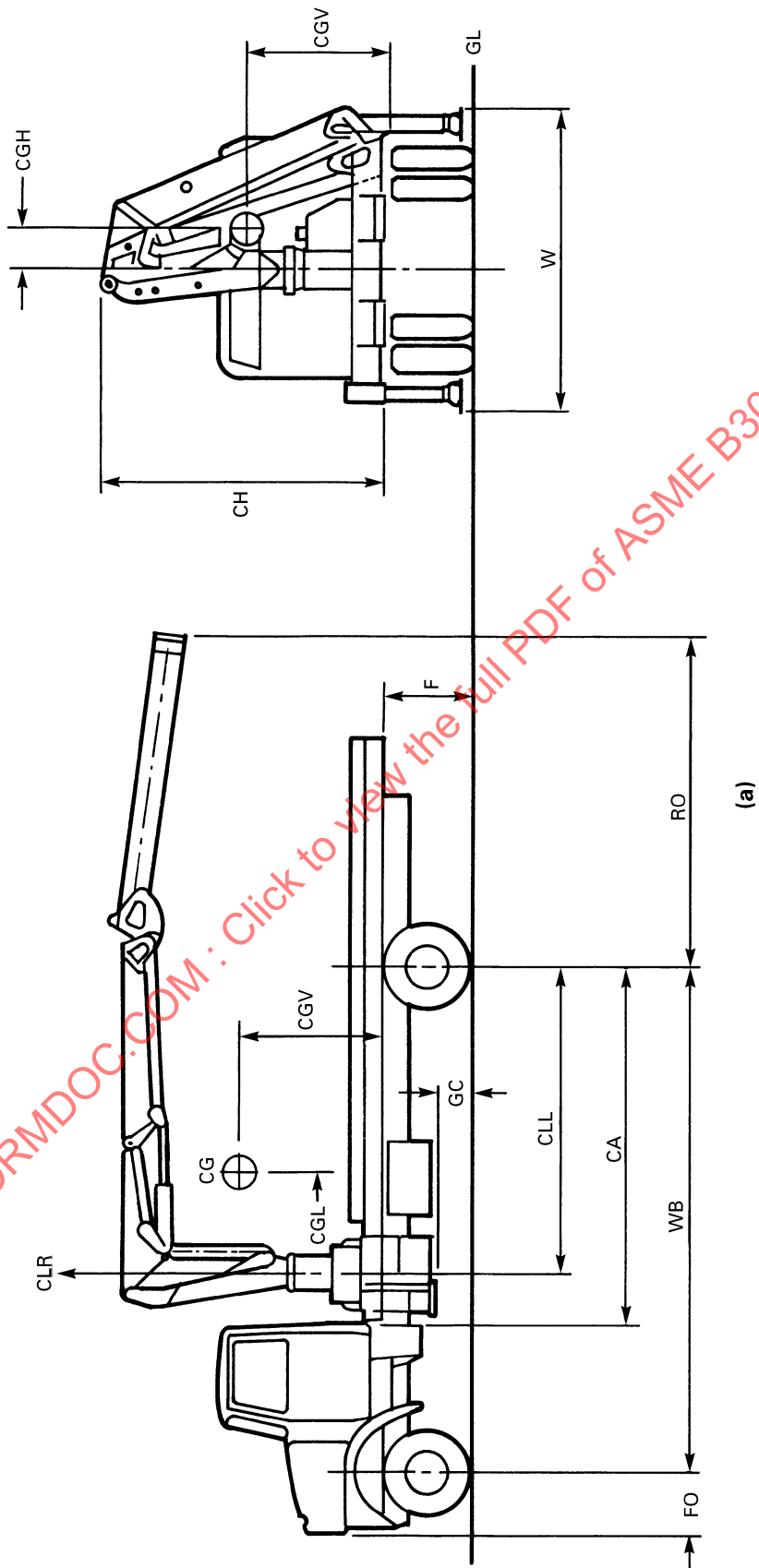

Fig. 22-0.3-1 Definitions of Specifications for Articulating Cranes (Cont'd)

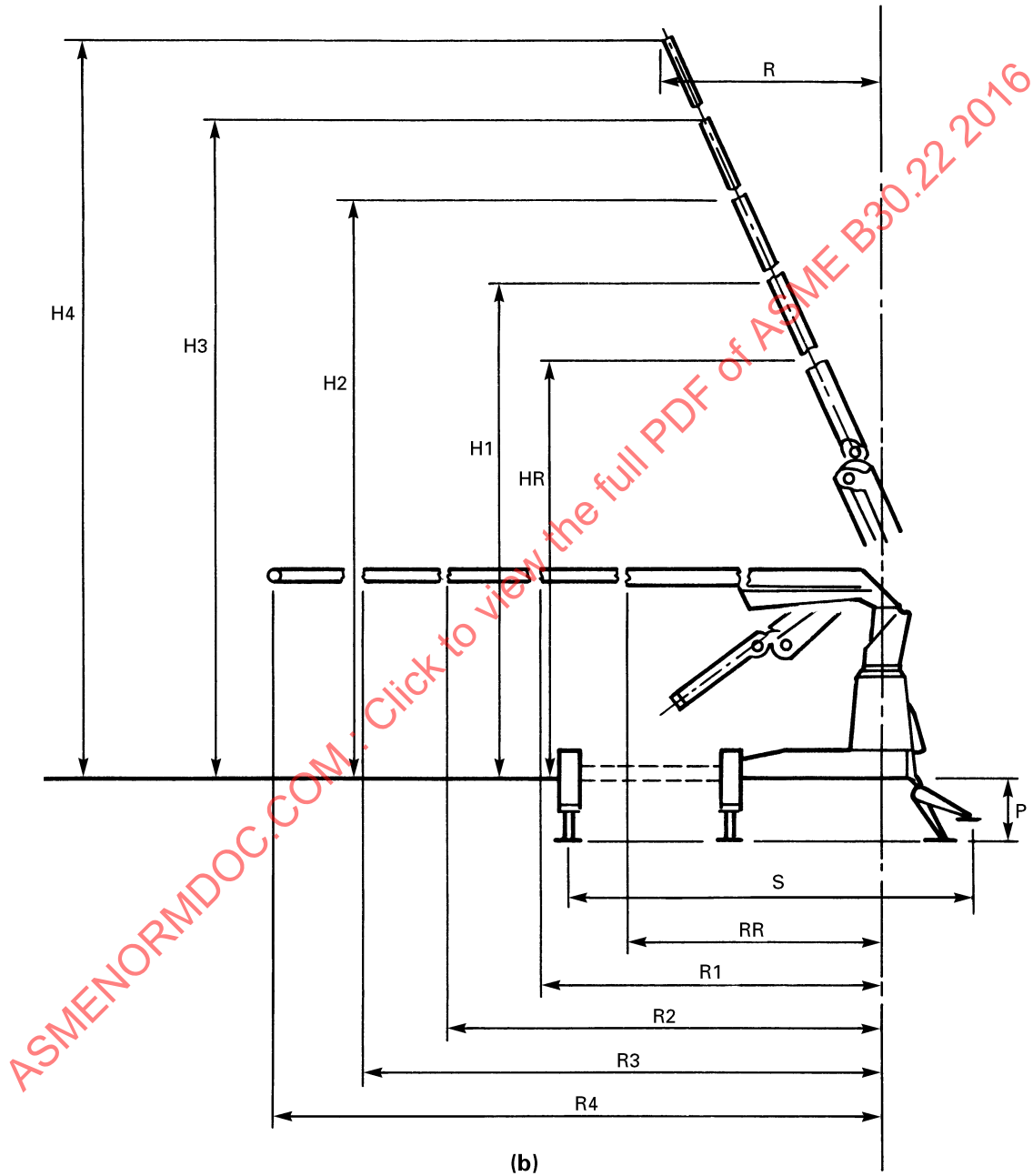
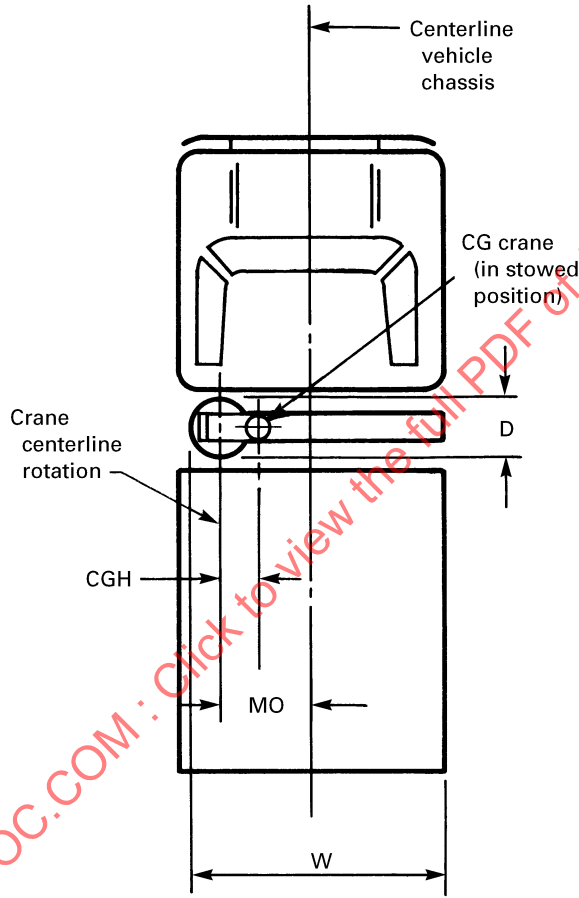

Fig. 22-0.3-1 Definitions of Specifications for Articulating Cranes (Cont'd)



(c)

ASMENORMDOC.COM : Click to view the full PDF of ASME B30.22-2016

Fig. 22-0.3-2 Hook Approach

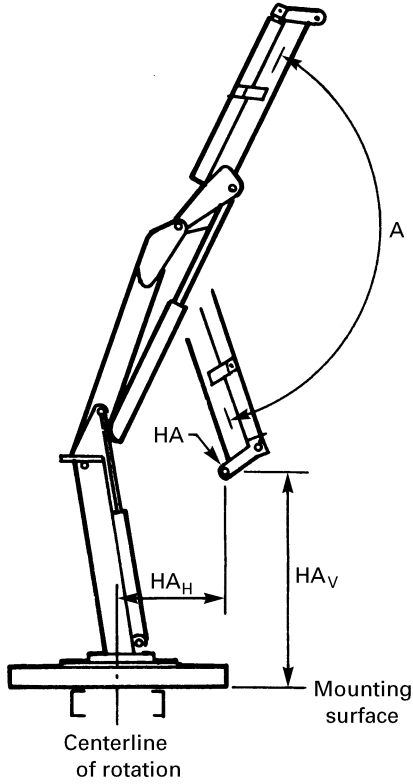

Fig. 22-0.3-4 Elevation Above Horizontal

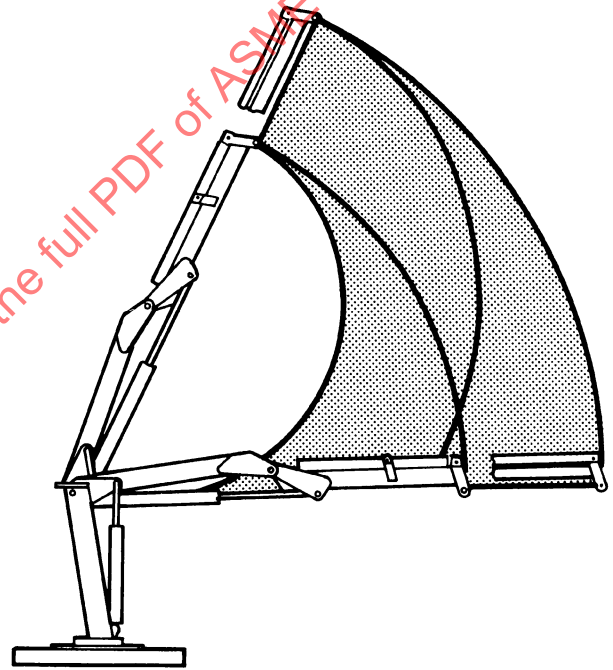
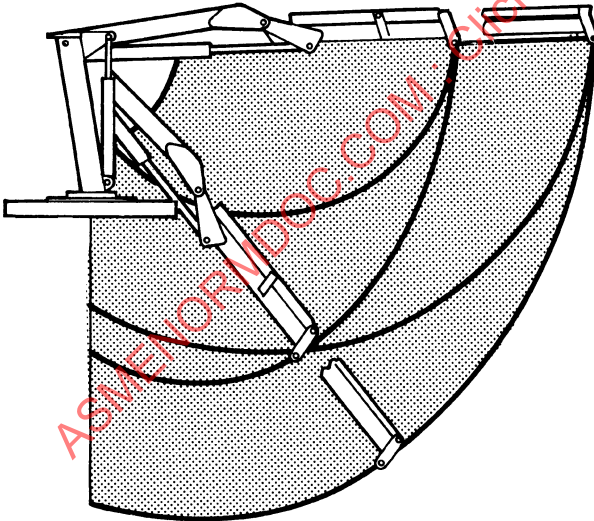

Fig. 22-0.3-3 Elevation Below Horizontal



E2 — elevation above horizontal

E1 — elevation below horizontal

SECTION 22-0.4: NOMENCLATURE FOR ARTICULATING CRANES

Figure 22-0.4-1 provides nomenclature for articulating cranes.

(16) SECTION 22-0.5: PERSONNEL COMPETENCE

Persons performing the functions identified in this Volume shall meet the applicable qualifying criteria stated in this Volume and shall, through education, training, experience, skill, and physical fitness, as necessary, be competent and capable to perform the functions as determined by the employer or employer's representative.

(16) SECTION 22-0.6: TRANSLATIONS OF SAFETY-RELATED INFORMATION AND CONTROL DESIGNATIONS

(a) *Translation of Non-English Documentation into English*

(1) The wording of written non-English safety information and manuals regarding use, inspection, and maintenance shall be translated into English using professional translation industry standards, which include, but are not limited to, the following:

(-a) translation of the complete paragraph message, instead of word by word

(-b) grammatical accuracy

(-c) respectfulness of the source document content without omitting or expanding the text

(-d) accurate translation of the terminology

(-e) reflection of the level of sophistication of the original document

(2) The finished translation shall be verified for compliance with (a)(1)(-a) through (a)(1)(-e) above by a qualified person having an understanding of the technical content of the subject matter

(3) Pictograms used to identify controls shall be described in the manuals. The pictograms should comply with ISO 7000, ISO 7296, or another recognized source, if previously defined. The text of the descriptions shall meet the criteria of (a)(1) and (a)(2) above.

(b) Any non-English documentation provided in addition to English shall be translated and reviewed in accordance with the requirements listed above.

SECTION 22-0.7: REFERENCES

(16)

Within the text, references are made to the following publications, copies of which may be obtained from the publishers as indicated.

ANSI/AWS D14.3, Welding Specifications for Earth Moving, Construction, and Agricultural Equipment
 Publisher: American Welding Society (AWS), 8669 NW 36 Street, No. 130, Miami, FL 33166 (www.aws.org)

ASME B30.5-2011, Mobile and Locomotive Cranes

ASME B30.10-2014, Hooks

ASME B30.23-2011, Personnel Lifting Systems

ASME B30.25-2013, Scrap and Material Handlers

ASME B30.26-2010, Rigging Hardware

ASME P30.1-2014, Planning for Load Handling Activities

Publisher: The American Society of Mechanical Engineers (ASME), Two Park Avenue, New York, NY 10016-5990 (www.asme.org)

ISO 7000:2014, Graphical symbols for use on equipment¹

ISO 7296:2012, Cranes — Graphic symbols¹

Publisher: International Organization for Standardization (ISO) Central Secretariat, Chemin de Blandonnet 8, Case Postale 401, 1214 Vernier, Geneva, Switzerland (www.iso.org)

SAE J765-Oct90, Crane Load Stability Test Code

SAE J1063-Nov93, Cantilevered Boom Crane Structures — Method of Test

SAE J2703-Oct08, Cranes — Access and Egress

SAE Z26.1-1996, Safety Glazing Materials for Glazing Motor Vehicles and Motor Vehicle Equipment Operating on Land Highways — Safety Standard

Publisher: SAE International (SAE), 400 Commonwealth Drive, Warrendale, PA 15096 (www.sae.org)

U.S. Department of Transportation Standards

Publisher: Superintendent of Documents, U.S. Government Publishing Office (GPO), 732 N. Capitol Street, NW, Washington, DC 20401 (www.gpo.gov)

¹ May also be obtained from the American National Standards Institute (ANSI), 25 West 43rd Street, New York, NY 10036 (www.ansi.org).

Fig. 22-0.4-1 Nomenclature for Articulating Cranes

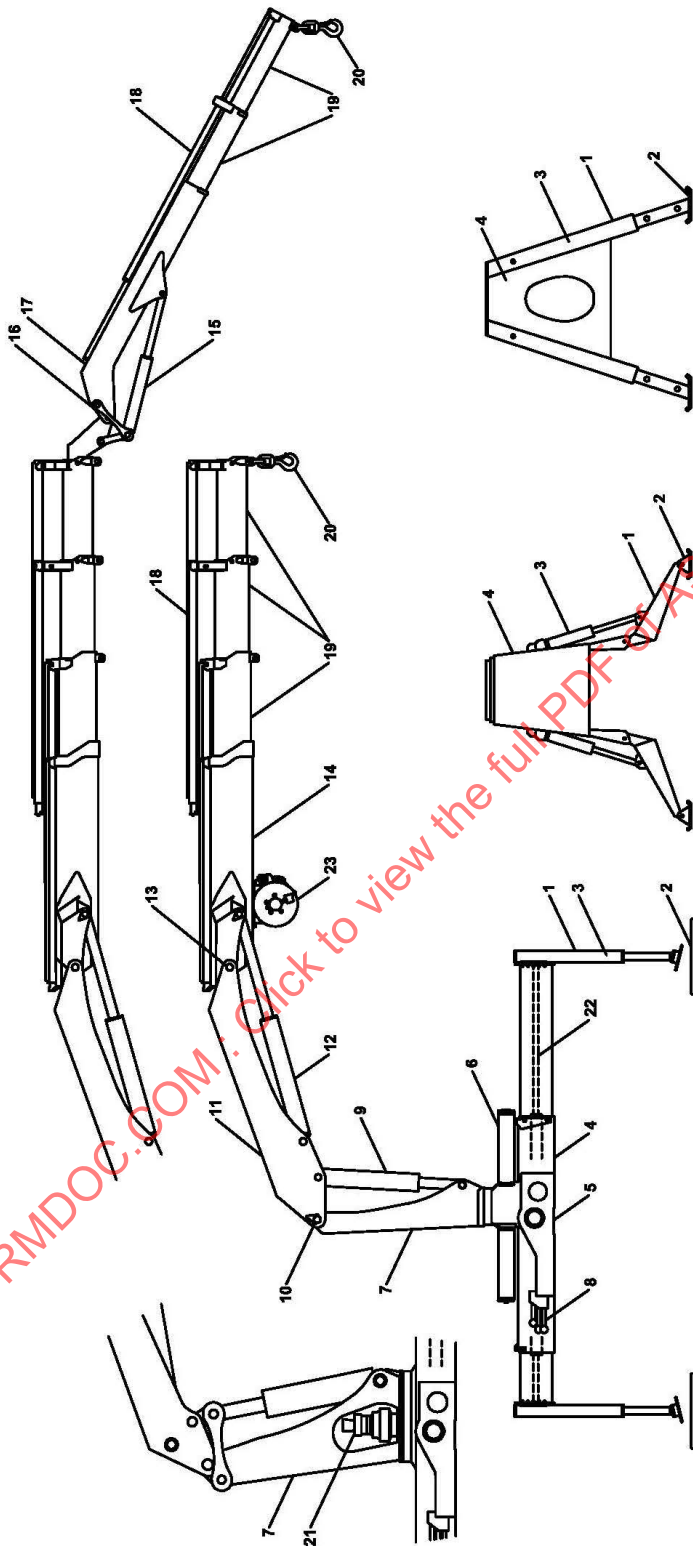

- Legend:**
- 1. Stabilizer
 - 2. Stabilizer pad
 - 3. Stabilizer cylinder, vertical
 - 4. Mainframe or base
 - 5. Mounting or suspension beam
 - 6. Rotation (slewing) cylinder type
 - 7. Mast or turntable
 - 8. Controls
 - 9. Inner boom lift cylinder
 - 10. Inner boom pivot
 - 11. Inner boom
 - 12. Outer boom cylinder
 - 13. Outer boom pivot
 - 14. Outer boom
 - 15. Jib (fly jib) boom cylinder
 - 16. Jib (fly jib) boom pivot
 - 17. Jib (fly jib) boom
 - 18. Boom extension cylinder(s)
 - 19. Boom extensions (one or more)
 - 20. Load hook
 - 21. Rotation (slewing) drive, gearbox type
 - 22. Stabilizer cylinder, horizontal
 - 23. Winch

(16)

Chapter 22-1

Construction and Characteristics

SECTION 22-1.1: LOAD RATINGS

(16) 22-1.1.1 Load Ratings Where Stability Governs Lifting Performance

(a) The margin of stability for determination of load ratings, with booms of stipulated lengths at stipulated working radii for the various types of crane mountings, is established by taking a percentage of the loads that will produce a condition of tipping or balance with the boom in the least stable direction, relative to the mounting. The load ratings shall not exceed the following percentages for cranes, when tested in accordance with SAE J765 for indicated types of mounting.

Type of Crane Mounting	Maximum Load Ratings, %
Wheel-mounted (including commercial truck, trailer, and off-road) crane with stabilizers extended and set	85
Wheel-mounted (including commercial truck, trailer, and off-road), using stabilizers partially extended and set	Notes (1) and (2)
Wheel-mounted (including commercial truck, trailer, and off-road), without stabilizer support	75
Railcar, without stabilizer support [Note (3)]	85
Crawler, without stabilizer support	75
Crawler, using stabilizers fully extended and set	85

NOTES:

- (1) The following equation shall be used for less than full extension of all stabilizer beams to find the rated capacity:

$$P \leq (T - 0.1F)/1.25$$

where

F = load applied at boom tip that gives the same moment effect as boom mass

P = rated capacity in the lifting direction specified

T = tipping load

- (2) If crane operation with stabilizers in positions other than fully extended is permitted by the crane manufacturer, specified procedures, ratings, and limitations for any configurations that are permitted shall be provided.
- (3) As a precaution while testing without stabilizer support, stabilizers should be loosely applied; rail clamps should not be used.

(b) The effectiveness of these preceding stability factors will be influenced by such additional factors as freely suspended loads; rail, wind, or ground conditions;

condition and inflation to tire manufacturer's highway-rated pressure of rubber tires; boom lengths; proper operating speeds for existing conditions; and, in general, careful and competent operation.

22-1.1.2 Load Ratings Where Factors Other Than Stability Govern Lifting Performance (16)

(a) Load ratings at some radii may be based on structural, mechanical, hydraulic, or pneumatic limitations rather than stability.

(b) A nonsymmetrical mounting requires a higher loading to produce a condition of tipping in a direction other than that of least stability on which the load ratings are established. Therefore, if the crane specification includes additional ratings for directions other than the least stable, such ratings also may be governed by structural competence rather than stability. For such specified additional ratings, the work area shall be indicated, and for those ratings which might be governed by tipping loads, the applicable percentage factors in para. 22-1.1.1(a) shall not be exceeded.

(c) For all operational applications, the crane load ratings established by the manufacturer shall not be exceeded.

22-1.1.3 Load Rating Charts (16)

(a) Durable rating charts with legible letters and figures shall be provided with each crane, one attached to the crane at each fixed operator station. On wired and wireless remote operated cranes, a chart shall be on the crane at ground level. One rating chart shall be in the operator's manual. The data and information to be provided on these charts shall include but not be limited to the following:

(1) a range of manufacturer's crane load ratings at stated operating radii, work areas, boom lengths, configurations, and jib lengths

(2) in areas where no load or reduced load is to be handled, a work area figure or load rating chart shall so state (see Fig. 22-1.1.3-1 for examples)

(3) levelness of the crane for rated loads

(4) if the crane is equipped with a winch, the line pull rating for all reeving (parts of line) configurations

(b) In addition to the data required on the load rating chart, the following information shall be shown either on the load rating chart or in the operating manual:

(1) recommended tire pressure chart, where applicable.

Fig. 22-1.1.3-1 Work Areas

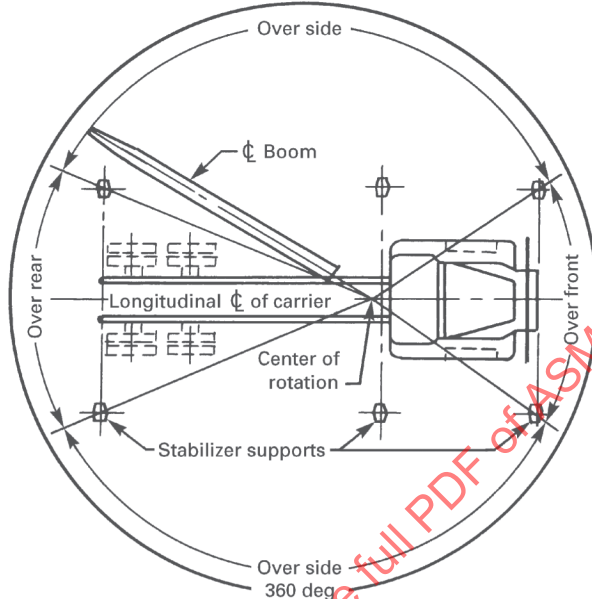

(a)

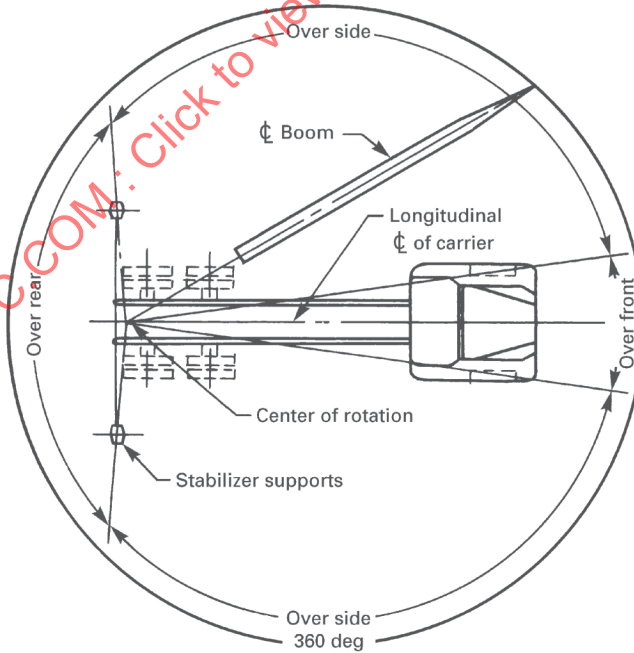

(b)

Fig. 22-1.1.3-1 Work Areas (Cont'd)

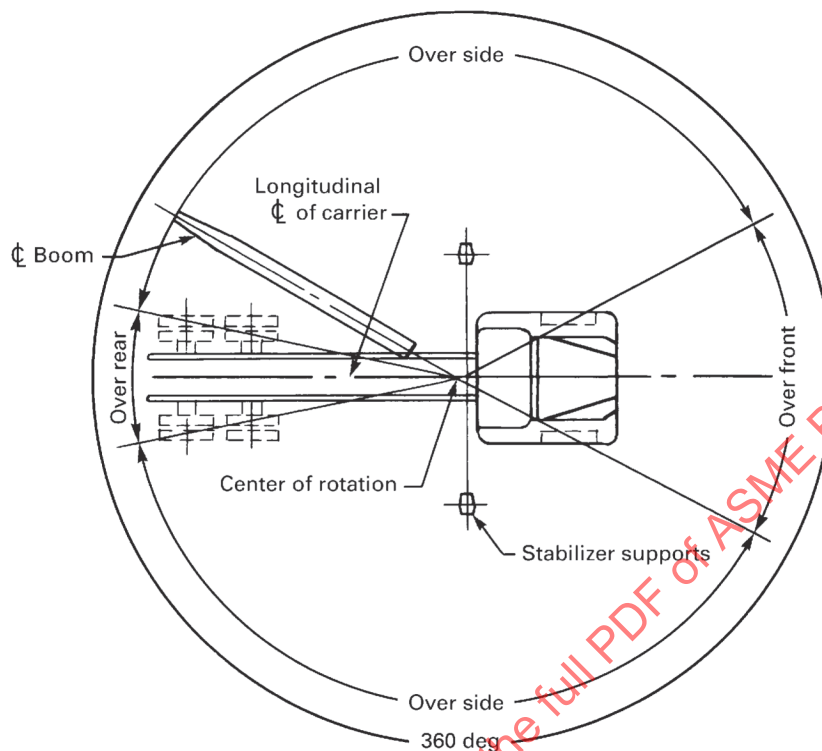

GENERAL NOTES:

- (a) These lines determine the limiting position of any load for operation within the working areas indicated.
- (b) Configurations that deviate significantly from the work areas shown in Fig. 22-1.1.3-1 shall have their working areas defined by appropriate sets of diagrams supplied by the manufacturer.

(2) cautionary or warning notes relative to limitations on equipment and operating procedures.

(3) the maximum telescopic travel length of each boom telescopic section.

(4) whether sections are telescoped with power or manually.

(5) sequence and procedure for extending and retracting telescopic boom section.

(6) maximum loads permitted during actual boom extending operation, and any limiting conditions, or cautions.

(7) hydraulic relief valve settings specified by the manufacture.

(8) if the crane is equipped with a load hoist mechanism, recommended parts of hoist reeving, size, length and type of rope for various crane loads, and recommended hoist reeving diagram. Sufficient information to permit the user to procure replacement wire rope shall be provided.

SECTION 22-1.2: BOOM LIFT, BOOM TELESCOPING, AND LOAD HOIST MECHANISMS

22-1.2.1 Inner, Outer, and Jib Boom Lift Mechanism

(a) The inner, outer, and jib boom cylinder(s) shall be capable of elevating, lowering, and controlling the booms with rated load and shall be capable of supporting the boom and rated load without action by the operator.

(b) An integrally mounted holding device (such as a load holding check valve) shall be provided on the cylinder(s) to prevent uncontrolled lowering of the boom(s) in the event of a hydraulic system failure (e.g., supply hose rupture).

22-1.2.2 Telescoping Boom(s)

(a) Extension and retraction of boom sections may be accomplished through hydraulic, mechanical, or manual means.

(b) The powered retract and extend functions shall be capable of controlling the rated load.

(c) An integrally mounted holding device (such as a load holding check valve) shall be provided on the cylinder(s) to prevent uncontrolled movement of the boom(s) in the event of a hydraulic system failure (e.g., supply hose rupture).

(16) 22-1.2.3 Load Hoist Mechanism (Load Hoist Equipped Machines Only)

(a) The hoist mechanism may consist of a winch or hydraulic cylinder(s) with necessary rope reeving.

(b) *Winch Assembly.* The winch drum assemblies shall have power and operational characteristics to perform all load lifting and lowering functions required in crane service when operated under recommended conditions.

(1) When brakes are used with winch drums, they shall be of the size and thermal capacity to control all rated crane loads with minimum recommended reeving. Brakes shall be provided with adjustments, when necessary, to compensate for lining wear and to maintain force in springs, where used.

(2) Winch drums shall have rope capacity with the recommended rope size and reeving to perform crane service within the range of boom lengths, operating radii, and vertical lifts specified by the manufacturer.

(-a) Not less than two full wraps of rope shall remain on the drum when the hook is in the extreme low position and the booms are at maximum elevation and extension. The drum shall be equipped with a minimum wrap limiter that prevents further lowering motion of the hoist when two wraps of rope remain.

(-b) The drum end of the rope shall be anchored to the drum by an arrangement specified by the crane or winch manufacturer.

(-c) The drum flange shall extend a minimum $\frac{1}{2}$ in. (13 mm) over the top layer of rope at all times.

(3) The winch drums shall provide a first layer rope pitch diameter of not less than 18 times the nominal diameter of the rope used.

(4) A means controllable from the operator's station shall be provided to hold the drum from rotating in the lowering direction and be capable of holding the rated load without further action by the operator.

(c) *Two-Block Damage-Prevention System.* On an articulating crane equipped with a winch, a two-block damage-prevention system or an anti-two-block device shall be provided. Stalling of the hydraulic system is acceptable.

NOTE: The winch drum diameters, minimum wraps, and flange height extension specified above are applicable to winch drums for wire rope. If synthetic rope is utilized, the minimum drum diameter, minimum wraps, and minimum flange height extension of the winch drum shall be as specified by the synthetic rope manufacturer or a qualified person.

(d) Cylinders With Rope Reeving

(1) Cranes using a load hoist mechanism with hydraulic cylinder(s) and rope reeving shall have power and operational characteristics to perform all load lifting and controlled lowering functions required in crane service when operated under recommended conditions.

(2) Cylinders utilized with a load hoist rope reeving system shall provide a working rope capacity (length) for that system with the recommended rope size and reeving to perform crane service with the range of boom lengths, operating radii, and vertical lifts specified by the manufacturer.

(3) Cylinders shall be equipped with a load-holding device to prevent uncontrolled lowering of the load in case of hydraulic line failure.

(4) The load hoist cylinder shall be capable of holding rated load without action of the operator.

SECTION 22-1.3: SWING MECHANISM

22-1.3.1 Swing Control

The swing mechanism shall start and stop with controlled acceleration and deceleration.

22-1.3.2 Swing Braking Means and Locking Devices

(a) A stopping means with holding power in both directions shall be provided to restrict movement of the rotating mast, when desired under normal operation. The braking means shall be capable of being set in the holding position and remaining so without further action by the operator.

(b) A positive locking device or boom support shall be provided to prevent the boom from rotating when in stowed position for transit.

SECTION 22-1.4: CRANE TRANSPORT

Commercial truck vehicle-mounted cranes shall meet applicable requirements of U.S. Department of Transportation Standards.

SECTION 22-1.5: ROPES AND REEVING ACCESSORIES

22-1.5.1 Rope Design Factors

(16)

(a) For supporting rated loads and for supporting the boom and working attachments at recommended travel or transit positions and boom lengths, the design factor for live or running ropes that wind on drums or travel over sheaves shall not be less than 3.5.

(b) For supporting the boom under recommended boom erection conditions, the design factor for live or running ropes shall not be less than 3.0.

(c) The design factors for rotation resistant ropes and synthetic ropes shall not be less than 5.0.

(d) The design factors specified in paras. 22-1.5.1(a) through 22-1.5.1(c) shall be the total minimum breaking force of all ropes in the system divided by the load imposed on the rope system when supporting the static weights of structure and crane rated load.

NOTE: *Minimum breaking force* was formerly referred to as *nominal breaking strength*.

(16) **22-1.5.2 Ropes**

(a) All ropes shall be of a specification recommended by the rope manufacturer, crane manufacturer, or a qualified person for the intended use.

(b) Socketing shall be done as recommended by the manufacturer of the assembly or a qualified person.

(c) If a load is supported by more than one part of rope, the tension in the parts shall be equalized.

(d) Wherever exposed to ambient temperatures at the rope in excess of 180°F (82°C), rope having an independent wire-rope core, wire-strand core, or other temperature-damage resistant core shall be used.

(e) Rotation-resistant ropes and fiber core ropes shall not be used for boom extension systems.

(16) **22-1.5.3 Reeving Accessories**

(a) Eye splices shall be made in a manner recommended by the rope or crane manufacturer, and rope thimbles should be used in the eye.

(b) Wire rope clips shall be drop-forged steel of the single-saddle- (U-bolt) or double-saddle-type clip. Malleable cast iron clips shall not be used. Wire rope clips shall be installed and assembled in accordance with ASME B30.26.

(c) Poured sockets, swaged, compressed, or wedge socket fittings shall be applied as recommended by the rope, crane, or fitting manufacturer.

(d) Wire rope clips used in conjunction with wedge sockets shall be attached in accordance with ASME B30.26. This does not preclude the use of devices specially designed for dead ending rope in a wedge socket.

22-1.5.4 Sheaves

(a) Sheave grooves shall be free from surface conditions which would cause rope damage. The cross-sectional radius at the bottom of the groove should be such as to form a close-fitting saddle for the size rope used, and the sides of the groove should be tapered outwardly to facilitate entrance of the rope into the groove. Flange corners should be rounded and the rims should run true about the axis of rotation.

(b) Sheaves carrying ropes that can be momentarily unloaded shall be provided with close-fitting guards or other devices to guide the rope back into the groove when the load is reapplied.

(c) The sheaves in the lower load block shall be equipped with close-fitting guards that will prevent

ropes from becoming fouled when the block is lying on the ground with ropes slack.

(d) All sheave bearings, except permanently lubricated bearings, shall be provided with means for lubrication.

22-1.5.5 Sheave Sizes

(16)

(a) Load hoisting sheaves, including those used in conjunction with cylinders to provide a rope reeving system, shall have pitch diameters not less than 18 times the nominal diameter of the rope used.

(b) Lower load block sheaves shall have pitch diameters of not less than 16 times the nominal diameter of the rope used.

(c) Boom extension system sheaves shall have a pitch diameter of not less than 15 times the nominal diameter of the rope.

NOTE: The diameters specified above are applicable to sheaves for wire rope. If synthetic rope is utilized, the minimum pitch diameters of the sheaves shall be as specified by the synthetic rope manufacturer or a qualified person.

22-1.5.6 Load Hooks, Ball Assemblies, and Load Blocks

Load hooks, ball assemblies, and load blocks shall be of sufficient weight to overhaul the line from the highest hook position for boom or boom and jib lengths, and the number of parts of line in use. Ball assemblies and load blocks shall be labeled with their rated capacity and weight. Hooks attached to the boom shall be labeled with their rated capacity. Hooks shall be equipped with latches unless the application makes the use of a latch impractical. When provided, the latch shall bridge the throat opening of the hook for the purpose of retaining slings, or other lifting devices, under slack conditions.

SECTION 22-1.6: CONTROLS

22-1.6.1 General

(16)

(a) Controls used during the crane operating cycle shall be located within reach of the operator while at the operator's station and labeled as to their designated function and direction of movement.

(b) Controls for "swing," "inner boom," "outer boom," "jib boom," "boom extensions," and "optional hydraulic equipment," shall be provided with means for holding in neutral position without the use of positive latches.

(c) Each control station, including remote control stations, shall be equipped with an "emergency stop" system, located at the operator's control station.

22-1.6.2 Control Forces and Movements

(a) Forces shall not be greater than 35 lb (156 N) on hand levers and not greater than 50 lb (222 N) on foot pedals.

(b) Travel distance on hand levers shall not be greater than 14 in. (356 mm) from neutral position on two-way levers, and not greater than 24 in. (610 mm) on one-way levers. Travel distance on foot pedals shall not be greater than 10 in. (254 mm).

22-1.6.3 Wireless (Radio) Remote Controls

(a) If interference or loss of the transmission of the wireless (radio) signal occurs, all movements shall stop and the remote control system shall be designed such that restarting is required before any movement resumes.

(b) When a wireless system is initially activated and a crane function control is selected, that function shall not activate.

(c) The crane's manual controls shall be inoperative when the remote controls are in use.

(d) The wireless remote shall be designed so that only one controller can operate the crane.

(16) SECTION 22-1.7: INSTALLATION

The crane manufacturer shall provide installation instructions, including the following:

(a) minimum frame strength [resistance to bending moment (RBM)] requirements for commercial truck mounting, or dynamic gross reactions (vertical force, torque, and moment) acting through the crane base for other mountings

(b) information about subframe types and design for commercial truck mountings, where applicable

(c) mounting bolt pattern, fastener types, and tightening torque sequence and values for vehicle mounting, and where different, for stationary mounting

(d) detailed load test and stability test procedures

(e) instructions for creating or obtaining custom load rating charts reflecting stability test results

(f) a predelivery inspection checklist

Installers shall follow all manufacturer's installation instructions. Where applicable installation instructions are no longer available from the crane manufacturer, a qualified person may provide instructions for the installation.

22-1.7.1 Testing

The installer shall perform tests on each crane installed in accordance with Section 22-2.2.

22-1.7.2 Exhaust Gases

Engine exhaust gases shall be piped and discharged in a direction away from the operator. All exhaust pipes shall be guarded or insulated to prevent contact by personnel when performing normal duties.

SECTION 22-1.8: CONSTRUCTION

22-1.8.1 Welding

All welding and welding operator qualifications for load sustaining members shall be in accordance with ANSI/AWS D14.3. Where special steels or other materials are used, the manufacturer shall provide welding procedures.

22-1.8.2 Operational Aids

The crane and/or device manufacturer's instructions shall describe the purpose of the device. The crane and/or device manufacturer shall provide recommendations for continued operation or shutdown of the crane if operational aids are inoperative or malfunctioning. Without such recommendations and any prohibitions from the manufacturer against further operation, the requirements of para. 22-3.2.2.(b) shall apply.

22-1.8.2.1 Two-Block Damage Prevention System or Anti-Two-Block Device. See para. 22-1.2.3(c).

22-1.8.2.2 Overload Protection Systems and Rated Capacity Limiters. An overload protection system or rated capacity limiter shall be provided. (16)

22-1.8.2.3 Crane Level Indicator. Means shall be provided for the operator to visually determine the levelness of the crane required by the manufacturer.

22-1.8.3 Hydraulic and Pneumatic Line Protection (16)

(a) Exposed lines subject to damage shall be protected insofar as it is practical.

(b) Hoses that contain fluid over 725 psi (5 MPa) or 122°F (50°C) and are within 3 ft (1 m) of a fixed control station shall be guarded to protect the operator.

22-1.8.4 Lubricating Points

Lubricating points should be accessible without the necessity of removing guards or other parts.

22-1.8.5 Stabilizers

(a) Means shall be provided to hold all stabilizers in the retracted position while in transit, and in the extended position for crane operation.

(b) Each power operated stabilizer shall be visible from an actuating location, unless the operator is assisted by a signalperson.

(c) Cylinders for vertical stabilization of the machine shall be equipped with an integrally mounted holding device (such as a pilot-operated check valve) to prevent loss of support under load in the event of a hydraulic system failure (e.g., supply hose rupture).

(d) Partially extended stabilizers — beams (if permitted), stabilizer beam position.

(1) A device or system shall be provided that accurately locates the stabilizer beam to coincide with the

partially extended stabilizer position(s) on the load rating chart.

(2) Visible indication of the manufacturer's specified stabilizer positions shall be provided by means such as stripes painted on the stabilizers, decals, or an electronic display.

22-1.8.6 Design Requirements

Prototype models of production articulating boom cranes shall meet applicable requirements of SAE J1063. On special design booms (not production models) or other special lift conditions, calculations to a standard, by a qualified person, or by the crane manufacturer, are acceptable.

(16) 22-1.8.7 Miscellaneous Equipment

(a) Means shall be provided for checking the manufacturer's specified pressure settings in each hydraulic circuit.

(b) Means shall be provided to hold the vehicle stationary while operating the crane.

(c) Handholds and steps shall be provided to an elevated operator station or cab, if equipped, and to elevated crane maintenance panels/doors and service points, in accordance with SAE J2703. Principal walking surfaces to elevated operator's stations, cabs, or maintenance and service points shall be of a skid-resistant type.

(d) If daily service or maintenance work must be performed from an elevated position, a platform or work positioning anchorages shall be provided.

(e) Platforms, if furnished, should comply with SAE J2703.

(16) 22-1.8.7.1 Cabs

(a) Cabs, if furnished, shall be constructed to protect the operator's station from the weather.

(b) All cab glazing shall be safety glazing material as defined in SAE Z26.1. Windows shall be provided in the front and on both sides of the cab with visibility forward and to either side. Visibility shall include a vertical range adequate to cover the boom point at all times. The front window may have a section that can be readily removed or held open, if desired. If the section is of the type held in the open position, it shall be secured to prevent inadvertent closure. A windshield wiper should be provided on the front window.

(c) All cab doors, whether of the sliding or swinging type, shall be restrained from inadvertent opening or closing while traveling or operating the machine. The door adjacent to the operator, if of the swinging type, should open outward and, if of the sliding type, should slide rearward to open.

(d) A clear passageway shall be provided from the operator's station to an exit door on the operator's side.

(e) A seat belt shall be provided in all single-control station, wheel-mounted cranes for use during transit and travel.

22-1.8.8 Replacement Parts

(16)

Replacement parts shall be manufactured by using at least the same design factors of the parts they are intended to replace.

SECTION 22-1.9: OPERATING MANUAL

(16)

The manufacturer shall furnish a crane operating and maintenance manual(s) with the crane. The manual(s) shall include operational safety guidance for the unit, crane operation instructions, crane specifications, and recommended service/maintenance information for the assembled unit.

Chapter 22-2

Inspection, Testing, and Maintenance

SECTION 22-2.1: INSPECTION

(16) 22-2.1.1 General

All inspections shall be performed by a designated person. Any deficiencies identified shall be examined and a determination made by a qualified person as to whether they constitute a hazard, and if so, what additional steps need to be taken to address the hazard.

(16) 22-2.1.2 Inspection Classification

(a) *Initial Inspection.* Prior to initial use, all new and altered cranes shall be inspected to verify compliance with the provisions of this Volume.

(b) *Regular Inspection.* Inspection procedure for cranes in regular service is divided into two general classifications based on the intervals at which inspection should be performed. The intervals depend on the nature of the critical components of the crane and the degree of their exposure to wear, deterioration, or malfunction. The two general classifications are herein designated as frequent and periodic, with respective intervals between inspections as defined.

(1) *Frequent Inspection.* Daily to monthly intervals.

(2) *Periodic Inspection.* One- to 12-month intervals, or as specifically recommended by the manufacturer or a qualified person.

(16) 22-2.1.3 Frequent Inspection

Items such as the following shall be inspected for defects at intervals as defined in para. 22-2.1.2(b)(1) or as specifically indicated by the manufacturer, including observation during operation for any deficiencies that might appear between regular inspections:

(a) all control mechanisms for maladjustment interfering with proper operation: daily, when used

(b) all control mechanisms for excessive wear of components and contamination by lubricants or other foreign matter

(c) operational aids for malfunction

(d) all hydraulic hoses, particularly those that flex in normal operation of crane functions, should be visually inspected once every working day, when used

(e) hooks and latches for deformation, chemical damage, cracks, and wear (refer to ASME B30.10)

(f) rope reeving for compliance with crane manufacturer's specifications

(g) electrical apparatus for malfunctioning, signs of excessive deterioration, dirt, and moisture accumulation

(h) hydraulic system for proper oil level and leaks: daily, when used

(i) tires for cuts and recommended inflation pressure

(j) wheels for loose nuts

(k) connecting pins and locking devices for wear and damage

(l) structural members for damage or deformation

22-2.1.4 Periodic Inspection

(16)

Complete inspections of the crane shall be performed at intervals as generally defined in para. 22-2.1.2(b)(2), depending on the crane's activity, severity of service, and environment, or as specifically indicated below. Dated records for periodic inspections shall be maintained.

These inspections shall include the requirements of para. 22-2.1.3 and items such as the following:

(a) deformed, cracked, or corroded members in the crane structure and entire boom.

(b) loose bolts or rivets.

(c) cracked or worn sheaves and drums.

(d) worn, cracked, or distorted parts such as pins, bearings, shafts, gears, rollers, and locking devices.

(e) excessive wear on brake and clutch system parts, linings, pawls, and ratchets.

(f) any significant inaccuracies of operational aids (refer to para. 22-2.1.5).

(g) lack of performance and compliance with safety requirements of gasoline, diesel electric, or other power plants.

(h) excessive wear of chain drive sprockets and excessive chain stretch.

(i) cracked crane hooks.

(j) malfunctioning travel steering, braking, and locking devices.

(k) excessively worn or damaged tires.

(l) hydraulic and pneumatic hose, fittings, and tubing
(1) evidence of leakage at the surface of the flexible hose or its junction with the metal end couplings.

(2) blistering or abnormal deformation of the outer covering of the hydraulic or pneumatic hose.

(3) leakage at threaded or clamped joints that cannot be eliminated by normal tightening or recommended procedures.

(4) evidence of excessive abrasion or scrubbing on the outer surface of a hose, rigid tube, or fitting. Means shall be taken to eliminate the interference of elements in contact or otherwise protect the components.

- (m) hydraulic and pneumatic pumps and motors
 - (1) loose bolts or fasteners
 - (2) leaks at joints between sections
 - (3) shaft seal leaks
 - (4) unusual noises or vibration
 - (5) loss of operating speed
 - (6) excessive heating of the fluid
 - (7) loss of pressure
- (n) hydraulic and pneumatic valves
 - (1) cracks in valve housing
 - (2) improper return of spool to neutral position
 - (3) leaks at spools or joints
 - (4) sticking spools
 - (5) failure of relief valves to attain correct pressure setting
 - (6) relief valve pressures as specified by the manufacturer
- (o) hydraulic and pneumatic cylinders
 - (1) drifting caused by fluid leaking across the piston
 - (2) rod seals leakage
 - (3) leaks at welded joints
 - (4) scored, nicked, or dented cylinder rods
 - (5) dented case (barrel)
 - (6) loose or deformed rod eyes or connecting joints
- (p) hydraulic filters, evidence of rubber particles on the filter element, which may indicate hose, "O" ring, or other rubber component deterioration. Metal chips or pieces on the filter may denote failure in pumps, motors, or cylinders. Further checking will be necessary to determine the origin of the problem before corrective action can be taken.
- (q) labels are in place and legible.

(16) 22-2.1.5 Operational Aids

- (a) Prior to daily operation, operational aids shall be inspected in accordance with the device/crane manufacturer's recommended procedures to determine if they are functioning properly.
- (b) Operational aids shall be inspected and tested in accordance with the device/crane manufacturer's recommended procedures as part of the periodic inspection of para. 22-2.1.4.
- (c) When operational aids are inoperative or malfunctioning, the crane and/or device, manufacturer's recommendations for continued operation or shutdown of the crane shall be followed until the problems are corrected [refer to para. 22-3.2.2(b)]. Without such recommendations and any prohibitions from the manufacturer against further operation, the requirements of para. 22-3.2.2(b) shall apply.

(16) 22-2.1.6 Cranes Not in Regular Use

- (a) A crane that has been idle for a period of 1 month or more, but less than 6 months, shall be given an inspection conforming with the requirements of paras. 22-2.1.3 and 22-2.4.2(a) before being placed in service.

- (b) A crane that has been idle for a period of over 6 months shall be given a complete inspection conforming with the requirements of paras. 22-2.1.3, 22-2.1.4, and 22-2.4.2 before being placed in service.

SECTION 22-2.2: TESTING

(16)

The following required tests should be conducted in the prescribed order as listed below: operational, load, and stability.

22-2.2.1 Operational Tests

(16)

- (a) Prior to initial use, all new and reinstalled cranes shall be tested by a designated person to verify compliance with the operational requirements of this section, including functions such as the following:
 - (1) load lifting and lowering mechanisms
 - (2) boom lifting and lowering mechanisms
 - (3) boom extension and retraction mechanism
 - (4) swinging mechanism
 - (5) travel mechanism
 - (6) operational aids
- (b) When the complete crane is not supplied by one manufacturer, such tests shall be conducted at final assembly.
- (c) Operational test results shall be made available.

22-2.2.2 Load Test

(16)

- (a) Prior to initial use, all new and reinstalled cranes shall be inspected and load tested by or under the direction of a qualified person. A written test report shall be prepared and placed on file. Test loads shall be as recommended by the crane manufacturer and shall not be less than 100% or more than 110% of rated load at a horizontal reach that is recommended by the manufacturer or a qualified person and produce the maximum bending moment through the crane base. Tests shall be conducted to the extent necessary to ensure compliance with the crane's maximum load ratings, including systems such as the following:
 - (1) boom(s) — elevating and lowering
 - (2) boom(s) — extending
 - (3) swing (slewing)
 - (4) operational aids
 - (5) optional attachments
- (b) The load tests shall consist of the following operations as a minimum requirement:
 - (1) Lift the test load to ensure that the load is supported by the crane.
 - (2) Swing the crane the full range of its swing.
 - (3) Articulate/extend the crane within the allowable working radius for the test load.
 - (4) For cranes equipped with a winch, hoist and lower the maximum load for the winch and ensure the load is held with the brake.

(c) The need for load testing of repaired, altered, or modified cranes shall be determined by a qualified person. When a load test is required, testing shall be in accordance with para. 22-2.2.2(b)(1) through (b)(4), as necessary, depending on the extent of the repair or alteration.

(16) 22-2.2.3 Stability Test

(a) Prior to use, all new and reinstalled vehicle-mounted cranes shall be stability tested by or under the direction of a qualified person. The test shall be conducted with the completed, unloaded vehicle on a firm, level surface. Tests shall be conducted in accordance with SAE J765. A written test report shall be prepared and kept on file. Test loads shall correspond with the inverse of the maximum load ratings percentage listed in para. 22-1.1.1 at the maximum horizontal reach and in the least stable direction(s) relative to the mounting.

(b) Operational aids that function to restrict the capacity of the crane may be temporarily overridden during the performance of the stability test, if required to handle the test load.

(c) The need for stability testing of a repaired, altered, or modified vehicle-mounted crane shall be determined by a qualified person. When a stability test is required, testing shall be in accordance with para. 22-2.2.3(a) and (b), as necessary, depending on the extent of the repair or alteration.

SECTION 22-2.3: MAINTENANCE

22-2.3.1 Preventive Maintenance

(a) A preventive maintenance program shall be established and should be based on the recommendations outlined in the crane manufacturer's manual. If a qualified person determines it is appropriate, the program should also include that individual's additional recommendations based on a review of the crane application and operations. Dated records should be placed on file.

(b) It is recommended that replacement parts be obtained from the original equipment manufacturer or be of equal quality.

(16) 22-2.3.2 Maintenance Procedure

(a) Before adjustments and repairs are started on a crane, the following precautions shall be taken as applicable:

(1) Place crane where it will cause the least interference with other equipment or operations in the area.

(2) Set all controls in the "OFF" position and ensure all operating features are secured from inadvertent motion.

(3) Render starting means inoperative.

(4) Stop power plant or disconnect at power takeoff.

(5) Lower the boom to the ground, if possible, or otherwise secure against dropping.

(6) Lower the lower load block to the ground or otherwise secure against dropping.

(7) Relieve hydraulic oil pressure from all hydraulic circuits before loosening or removing hydraulic components.

(b) "Warning" or "Out of Order" signs shall be placed on the crane controls. Signs shall be removed only by authorized personnel.

(c) After adjustments and repairs have been made, the crane shall not be returned to service until all guards have been reinstalled, trapped air removed from the hydraulic system, and maintenance equipment removed.

22-2.3.3 Adjustments, Alterations, and Repairs

(16)

(a) Any hazardous conditions disclosed by the inspection requirements of Section 22-2.1 shall be corrected before operation of the crane is resumed. Adjustments, alterations, and repairs shall be done only by designated personnel.

(b) Adjustments shall be made within the manufacturer's specified tolerances to maintain correct functioning of components. The following are examples of components that may need adjustment:

(1) functional operating mechanisms

(2) operational aids

(3) pneumatic, electronic, hydraulic, and mechanical control systems

(4) power plants

(5) braking systems

(c) Repairs or replacements shall be provided as needed for operation. The following are examples:

(1) critical parts of functional operating mechanisms that are cracked, broken, corroded, bent, or excessively worn.

(2) critical parts of the crane structure that are cracked, bent, broken, or excessively corroded.

(3) damaged or worn hooks as described under "Maintenance" in ASME B30.10. Repairs by welding or reshaping are not recommended.

(d) Repairs shall be made according to the manufacturer's instructions if instructions are available. Absent instructions from the manufacturer, repairs shall be made according to the directions of a qualified person.

(e) Repairs shall return the crane to a condition of structural, mechanical, and functional integrity to permit operation of the crane in accordance with the manufacturer's published performance specifications.

(f) Alterations shall only be performed according to instructions from the manufacturer. Absent instructions from the manufacturer, a qualified person may provide instructions for the alteration.

(g) Instructions shall be provided by the manufacturer for the removal of air from hydraulic circuits.

22-2.3.4 Lubrication

(a) All moving parts of the crane for which lubrication is specified should be regularly lubricated. Lubricating systems should be checked for proper delivery of lubricant. Care should be taken to follow the manufacturer's recommendations as to the points and frequency of lubrication, maintenance of lubricant levels, and types of lubricant to be used.

(b) Machinery shall be stationary while lubricants are being applied and protection provided as called for in paras. 22-2.3.2(a)(2) through 22-2.3.2(a)(5), unless equipped for automatic or remote lubrication.

SECTION 22-2.4: ROPE INSPECTION, REPLACEMENT, AND MAINTENANCE

(16) 22-2.4.1 General

All inspections shall be performed by a designated person. Any deficiencies identified shall be examined and a determination made by a qualified person as to whether they constitute a hazard, and if so, what additional steps need to be taken to address the hazard.

Due to crane design configuration to maintain mobility, sheave diameters, drum diameters, and rope design factors are limited. Because of these limited design parameters, inspection to detect deterioration in accordance with para. 22-2.4.2 and timely replacement in accordance with para. 22-2.4.3 are essential. If synthetic ropes are provided in lieu of wire ropes, the inspection, replacement, and maintenance criteria for the rope shall be provided by the synthetic rope manufacturer or a qualified person.

(16) 22-2.4.2 Inspection

(a) Frequent Inspection

(1) All running ropes in service should be visually inspected once each working day. A visual inspection shall consist of observation of all rope that can reasonably be expected to be in use during the day's operations. These visual observations should be concerned with discovering gross damage that may be an immediate hazard, including the following:

(-a) distortion of the rope such as kinking, crushing, unstranding, birdcaging, main strand displacement, or core protrusion. Loss of rope diameter in a short rope length or unevenness of outer strands should provide evidence that the rope or ropes must be replaced.

(-b) general corrosion.

(-c) broken or cut strands.

(-d) number, distribution, and type of visible broken wires [see paras. 22-2.4.3(b)(1), 22-2.4.3(b)(2), and 22-2.4.3(b)(7) for further guidance].

(-e) core failure in rotation-resistant ropes (see Fig. 22-2.4.2-1). When such damage is discovered, the rope shall be either removed from service or given an inspection as detailed in para. 22-2.4.2(b).

(2) Care shall be taken when inspecting sections of rapid deterioration such as flange points, crossover points, and repetitive pickup points on drums.

(3) Care shall be taken when inspecting rotation-resistant ropes, because of their higher susceptibility to damage and increased deterioration when working on equipment with limited design parameters. The internal deterioration of rotation-resistant ropes may not be readily observable.

(b) Periodic Inspection

(1) The inspection frequency shall be determined by a qualified person and shall be based on such factors as expected rope life as determined by experience on the particular installation or similar installations, severity of environment, percentage of capacity lifts, frequency rates of operation, and exposure to shock loads. Inspections need not be at equal calendar intervals and should be more frequent as the rope approaches the end of its useful life. This inspection shall be performed at least annually.

(2) This inspection shall cover the entire length of the rope. Only the surface wires of the rope need be inspected. No attempt should be made to open the rope. Any deterioration resulting in an appreciable loss of original strength, such as the conditions described below, shall be noted and determination made as to whether further use of the rope would constitute a hazard.

(-a) points listed in para. 22-2.4.2(a)

(-b) reduction of rope diameter below nominal diameter due to loss of core support or internal or external corrosion

(-c) severely corroded or broken wires at end connections

(-d) severely corroded, cracked, bent, worn, or improperly applied end connections

(3) Care shall be taken when inspecting sections of rapid deterioration, such as the following:

(-a) sections in contact with saddles, equalizer sheaves, or other sheaves where rope travel is limited

(-b) sections of the rope at or near terminal ends where corroded or broken wires may protrude

22-2.4.3 Rope Replacement

(a) No precise rules can be given for determination of the exact time for rope replacement since many variable factors are involved. Once a rope reaches anyone of the specified removal criteria, it may be allowed to operate to the end of the work shift, based on the judgment of a qualified person. The rope shall be replaced after that work shift, at the end of the day, or at the latest time prior to the equipment being used by the next work shift.

(b) Removal criteria for rope replacement shall be as follows:

(1) broken wires

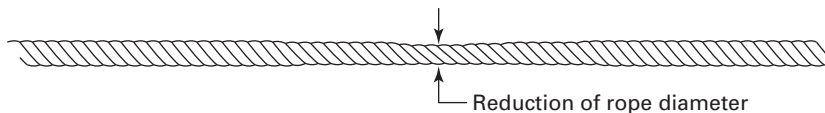
Fig. 22-2.4.2-1 Core Failure in 19 × 7 Rotation-Resistant Rope

GENERAL NOTE: Note the lengthening of lay and reductions of diameter.

(-a) in running ropes, six randomly distributed broken wires in one lay or three broken wires in one strand in one lay

(-b) in rotation-resistant ropes, two randomly distributed broken wires in six rope diameters or four randomly distributed broken wires in 30-rope diameters

(2) one outer wire broken at the point of contact with the core of the rope that has worked its way out of the rope structure and protrudes or loops out from the rope structure. Additional inspection of this section is required.

(3) independent wire rope core (IWRC) or strand core protrusion between the outer strands.

(4) kinking, crushing, birdcaging, or any other damage resulting in distortion of the rope structure.

(5) apparent damage from any heat source, including, but not limited to, welding, power line strikes, or lightning.

(6) reduction from nominal diameter of more than 5%.

(7) severe corrosion as evidenced by pitting.

(8) deviation shall be allowed from the removal criteria listed in paras. 22-2.4.3(b)(1) through 22-2.4.3(b)(7) only with written approval of the manufacturer of the specific wire rope.

(c) Broken wire removal criteria cited in this Volume applies to wire rope operating on multilayer drums regardless of sheave material.

(d) Replacement rope shall have the same or higher minimum breaking force as the original rope furnished or recommended by the crane manufacturer. Any deviation from the original size, grade, or construction shall be specified by a rope manufacturer, the crane manufacturer, or a qualified person.

(e) Ropes not in regular use: All rope that has been idle for a period of a month or more due to shutdown or storage of a crane on which it is installed shall be given an inspection in accordance with para. 22-2.4.2(b) before it is placed in service. This inspection shall be for all types of deterioration and shall be performed by a designated person.

(f) *Inspection Records*

(1) *Frequent Inspection.* No records required.

(2) *Periodic Inspection.* To establish data as a basis for judging the proper time for replacement, a dated report of rope condition at each periodic inspection shall

be kept on file. This report shall cover points of deterioration listed in para. 22-2.4.2(b)(2). If the rope is replaced, only the fact that the rope was replaced need be recorded.

(g) A long-range inspection program should be established and should include records on the examination of ropes removed from service so that a relationship can be established between visual observation and actual condition of the internal structure.

22-2.4.4 Rope Maintenance

(a) Rope should be stored to prevent damage or deterioration.

(b) Unreeling or uncoiling of rope shall be done as recommended by the rope manufacturer and with care to avoid kinking or inducing a twist.

(c) Prior to cutting a wire rope, seizings shall be placed on each side of the point to be cut. The minimum length of each seizing shall be equal to or exceed the nominal diameter of the wire rope to which it is being applied. Seizing may consist of wire, strand, tape, or other material as long as the seizing holds the wires and strands firmly in place during the rope's cutting and handling. The required number of seizings is as follows:

(1) on preformed wire rope, one seizing on each side of the point to be cut

(2) on nonpreformed wire rope, at least three seizings on each side of the wire rope to be cut

(d) During installation, care should be exercised to avoid dragging of the rope in dirt or around objects that will scrape, nick, crush, or induce sharp bends in it.

(e) Rope should be maintained in a well-lubricated condition. It is important that lubricant applied as part of a maintenance program shall be compatible with the original lubricant, and to this end, the rope manufacturer should be consulted; lubricant applied shall be of the type that does not hinder visual inspection. Those sections of rope that are located over sheaves or otherwise hidden during inspection and maintenance procedures require special attention when lubricating rope. The object of rope lubrication is to reduce internal friction and to prevent corrosion.

(f) When an operating rope shows greater wear at well-defined localized areas than on the remainder of the rope, rope life can be extended (in cases where a reduced rope length is adequate) by cutting off a section at the worn end, and thus shifting the wear to different areas of the rope.

Chapter 22-3 Operation

SECTION 22-3.1: QUALIFICATIONS AND RESPONSIBILITIES

(16) 22-3.1.1 Operators

Cranes shall be operated only by the following personnel:

(a) those who have met the requirements of paras. 22-3.1.2(a) through 22-3.1.2(c) and 22-3.1.2(f).

(b) those who have met the requirements of para. 22-3.1.2(d) and who are training for the type of crane being operated. While operating the crane, the trainee must be under the supervision of a designated person. The number of trainees permitted to be supervised by a single designated person, the physical location of the designated person while supervising, and the type of communication required between the designated person and the trainee shall be determined by a qualified person.

(c) maintenance personnel who have completed all operator trainee qualification requirements. Operation by these persons shall be limited to those crane functions necessary to perform maintenance on the crane or to verify the performance of the crane after maintenance has been performed.

(d) inspectors who have completed all operator trainee qualification requirements. Operation by these persons shall be limited to those crane functions necessary to accomplish the inspection.

22-3.1.2 Qualifications for Operators

(a) Operator and operator trainees shall meet the following physical qualifications unless it can be shown that failure to meet the qualifications will not affect the operation of the crane. In such cases, specialized clinical or medical judgments and tests may be required.

(1) vision of at least 20/30 Snellen in one eye and 20/50 in the other, with or without corrective lenses.

(2) ability to distinguish colors, regardless of position, if color differentiation is required.

(3) adequate hearing to meet operational demands, with or without hearing aid.

(4) sufficient strength, endurance, agility, coordination, and speed of reaction to meet the operation demands.

(5) normal depth perception, field of vision, reaction time, manual dexterity, coordination, and no tendencies to dizziness or similar undesirable characteristics.

(6) a negative result for a substance abuse test. The level of testing will be determined by the standard practice for the industry where the crane is employed and this test shall be confirmed by a recognized laboratory service.

(7) no evidence of having physical defects or emotional instability that could render a hazard to the operator or others, or that in the opinion of the examiner could interfere with the operator's performance. If evidence of this nature is found, it may be sufficient cause for disqualification.

(8) no evidence of being subject to seizures or loss of physical control; such evidence shall be sufficient reason for disqualification. Specialized medical tests may be required to determine these conditions.

(b) Operator requirements shall include, but not be limited to, the following:

(1) evidence of successfully passing a physical examination as defined in para. 22-3.1.2(a).

(2) satisfactory completion of a written examination covering operational characteristics, controls, and emergency control skills, such as response to fire, power line contact, loss of stability, or control malfunction, as well as characteristic and performance questions appropriate to the crane type for which qualification is being sought.

(3) demonstrated ability to read, write, comprehend, and use arithmetic and a load rating chart, in the language of the crane manufacturer's operation and maintenance instruction materials.

(4) satisfactory completion of a combination written and verbal test on load rating chart usage that covers a selection of the configurations (the crane may be equipped to handle) for the crane type for which qualification is being sought.

(5) satisfactory completion of an operation test demonstrating proficiency in performing lifting, lowering, booming, telescoping, and swinging functions at various radii as well as shutdown. Testing shall also include proficiency in prestart and poststart inspection, securing procedures, and traveling by appropriate written, oral, or practical methods.

(6) demonstrated understanding of the applicable sections of the B30 Standard and federal, state, and local requirements.

(c) Operators who have successfully qualified for a specific crane type shall be requalified, if supervision

deems it necessary. Requalification shall include, but not be limited to, the following:

(1) evidence of successfully passing a current physical examination as defined in para. 22-3.1.2(a)

(2) satisfactory completion of a written examination covering operational characteristics, controls, and emergency control skills, such as response to fire, power line contact, loss of stability, or control malfunction, as well as characteristic and performance stability questions appropriate to the crane type for which requalification is being sought

(3) demonstrated ability to read, write, comprehend, and use arithmetic and a load rating chart, in the language of the crane manufacturer's operation and maintenance instruction materials

(4) satisfactory completion of a combination written and verbal test on load rating chart usage that covers a selection of the configurations (the crane may be equipped to handle) for the crane type for which requalification is being sought

(5) satisfactory completion of an operation test demonstrating proficiency in handling the specific crane type for which requalification is being sought, including both prestart and poststart inspections, maneuvering skills, shutdown, and securing procedures

(6) demonstrated understanding of the applicable sections of the B30 Standard and federal, state, and local safety requirements

(d) Trainee qualification requirements shall include, but not be limited to, the following:

(1) evidence of successfully passing a current physical examination as defined in para. 22-3.1.2(a)

(2) satisfactory completion of a written examination covering safety, operational characteristics and limitations, and controls of the crane type for which qualification is being sought

(3) demonstrated ability to read, write, comprehend, and use arithmetic and a load rating chart, in the language of the crane manufacturer's operations and maintenance instruction materials

(4) satisfactory completion of a combination written and verbal test on load rating chart usage covering various crane configurations

(e) Trainee qualification, operator qualification, and operator requalification shall be performed by a designated person who, by experience and training, fulfills the requirements of a qualified person.

(f) Operator physical examinations, as defined in para. 22-3.1.2(a), shall be required every 3 yr or more frequently, if supervision deems it necessary.

(16) 22-3.1.3 Responsibilities

While the organizational structure of various projects may differ, the following roles are described here for

purposes of delineating responsibilities. All responsibilities listed below shall be assigned in the work site organization. (A single individual may perform one or more of these roles.)

crane operator: directly controls the crane's functions.

crane owner: has custodial control of a crane by virtue of lease or ownership.

crane user: arranges the crane's presence on a work site and controls its use there.

lift director: directly oversees the work being performed by a crane and the associated rigging crew.

rigger: attaches the load to be lifted to the crane hook using slings, shackles, spreader beams, safety hoist rings, etc., and other gear as appropriate.

site supervisor: exercises supervisory control over the work site on which a crane is being used and over the work which is being performed on that site.

22-3.1.3.1 Responsibilities of the Crane Owner and Crane User.

In some situations the owner and the user may be the same entity and is therefore accountable for all of the following responsibilities. In other cases, the user may lease or rent a crane from the owner without supervisory, operational, maintenance, support personnel, or services from the owner. In these situations, paras. 22-3.1.3.1.1 and 22-3.1.3.1.2 shall apply.

22-3.1.3.1.1 Responsibilities of the Crane Owner. (16)

The crane owner's responsibilities shall include the following:

(a) provide a crane that meets the requirements of Chapters 22-1 and 22-2 of the applicable volume as well as specific job requirements defined by the user

(b) provide a crane and all necessary components, specified by the manufacturer, that meets the user's requested configuration and capacity

(c) provide all applicable load rating chart(s) and diagrams

(d) provide additional technical information pertaining to the crane, necessary for crane operation, when requested by the crane user

(e) provide operating and maintenance manuals, maintenance information, and warning decals and placards installed as prescribed by the crane manufacturer

(f) establish an inspection, testing, and maintenance program in accordance with Chapter 22-2 and inform the crane user of the requirements of this program

(g) use designated or qualified personnel as defined in Chapter 22-2 for the inspection, maintenance, or repair requirements outlined in this Volume

22-3.1.3.1.2 Responsibilities of the Crane User. (16)

The crane user's responsibilities shall include the following:

(a) comply with the requirements of this Volume, manufacturer's requirements, and those regulations applicable at the work site.

(b) address safety concerns raised by the operator or other personnel and being responsible if he decides to overrule those concerns and directs crane operations to continue. In all cases, the manufacturer's criteria for safe operation and the requirements of this Volume shall be adhered to.

(c) determine if additional regulations are applicable to crane operations.

(d) use crane operators that meet the requirements of paras. 22-3.1.1 and 22-3.1.2 and are qualified to perform the tasks that will be required with the crane which they are assigned to operate.

(e) inform the crane operator of the weight of loads to be lifted, as well as the lifting, moving, and placing locations for these loads.

(f) ensure that a crane's load rigging is performed by a designated person.

(g) appoint the signalperson(s) and convey that information to the crane operator.

(h) ensure that signalperson(s) appointed understands crane operation, limitations, and standard hand signals (see Fig. 22-3.3.4-1 for hand signals).

(i) ensure the assigned operator(s) has been notified of adjustments or repairs that have not yet been completed, prior to commencing crane operations.

(j) ensure that the operator has been informed who the designated person is for the purposes of reporting the need for any adjustments or repairs.

(k) use personnel that meet the requirements for a qualified or designated person for inspections as required in Section 22-2.1.

(l) use personnel that meet the requirements for a designated person for the purposes of maintenance and/or repair.

(m) ensure that all personnel involved in maintenance, repair, and inspection are aware of their responsibilities, assigned duties, and the associated hazards.

(n) ensure that the inspection, testing, and maintenance programs specified by the crane owner are followed.

(o) ensure that the applicable requirements of para. 22-3.2.7 are met when lifting personnel.

(b) ensure that the area for the crane is adequately prepared. The preparation includes, but is not limited to, the following:

(1) access roads for the crane and associated equipment

(2) an operating area that is suitable for the crane with respect to levelness, surface conditions, support capability, proximity to power lines, excavations, slopes, underground utilities, subsurface construction, and obstructions to crane operation

(3) traffic control as necessary to restrict unauthorized access to the crane's working area

(c) ensure that conditions which may adversely affect crane operations are addressed. Such conditions include, but are not limited to, the following:

- (1) poor soil conditions
- (2) wind velocity or gusting winds
- (3) heavy rain
- (4) fog
- (5) extreme cold
- (6) artificial lighting

(d) allow crane operation near electric power lines only when the requirements of Section 22-3.4 have been met.

22-3.1.3.2.2 Responsibilities of the Lift Director. (16)

The lift director's responsibilities shall include the following:

(a) be present at the job site during lifting operations.

(b) stop crane operations if alerted to an unsafe condition affecting those operations.

(c) ensure that the preparation of the area needed to support crane operations has been completed before crane operations commence.

(d) ensure necessary traffic controls are in place to restrict unauthorized access to the crane's work area.

(e) ensure that personnel involved in crane operations understand their responsibilities, assigned duties, and the associated hazards.

(f) address safety concerns raised by any personnel and being responsible if he decides to overrule those concerns and directs crane operations to continue. (In all cases, the manufacturer's criteria for safe operation and the requirements of this Volume shall be adhered to.)

(g) appoint the signalperson(s) and convey that information to the crew.

(h) ensure that signalperson(s) appointed meet the requirements of para. 22-3.3.3.

(i) allow crane operation near electric power lines only when the requirements of Section 22-3.4 and any additional requirements determined by the site supervisor have been met.

(j) ensure that the requirements of para. 22-3.2.7 are met when lifting personnel.

- (16) **22-3.1.3.2 Responsibilities of the Site Supervisor and Lift Director.** In some situations the site supervisor and lift director may be the same person and is therefore accountable for all of the responsibilities listed in paras. 22-3.1.3.2.1 and 22-3.1.3.2.2.

- (16) **22-3.1.3.2.1 Responsibilities of the Site Supervisor.** The site supervisor's responsibilities shall include the following:

(a) ensure that crane operations are coordinated with other job site activities that will be affected by or will affect lift operations.

(k) inform the crane operator of the weight of loads to be lifted, as well as the lifting, moving, and placing locations for these loads.

(l) obtain the crane operator's verification that this weight does not exceed the crane's rated capacity.

(m) ensure that a crane's load rigging is performed by designated personnel.

22-3.1.3.3 Responsibilities of Crane Operators and Riggers. In some cases, the crane operator and rigger may be the same person. The operator shall be responsible for the following listed items. The operator shall not be responsible for hazards or conditions that are not under his direct control and that adversely affect the lift operations. Whenever the operator has doubt as to the safety of crane operations, the operator shall stop the crane's functions in a controlled manner. Lift operations shall resume only after safety concerns have been addressed.

(16) **22-3.1.3.3.1 Responsibilities of the Crane Operator.** The crane operator's responsibilities shall include the following:

(a) not operate the crane when physically or mentally unfit.

(b) know what types of site conditions could adversely affect the operation of the crane and determine the possible presence of those conditions.

(c) know and follow the procedures specified by the manufacturer or approved by a qualified person for setting up and reeving the crane.

(d) understand and apply the information contained in the crane manufacturer's operating manual.

(e) ensure that all controls are in the "OFF" or neutral position and that all personnel are in the clear before energizing the crane or starting the engine.

(f) perform daily inspection as specified in paras. 22-2.1.2 and 22-2.4.2.

(g) promptly report the need for any adjustments or repairs to a designated person.

(h) follow applicable lock out/tag out procedures.

(i) observe each stabilizer during extension, setting, and retraction, or use a signalperson to observe each stabilizer during extension, setting, or retraction.

(j) understand and avoid all boom and load crush zones and pinch-points.

(k) understand the crane's functions and limitations as well as its particular operating characteristics.

(l) test the crane function controls that will be used to operate the crane and validate that those function controls respond properly.

(m) not engage in any practice that will divert their attention while actually operating the crane controls.

(n) use the crane's load rating chart(s) and diagrams and apply all notes and warnings related to the charts, to confirm the correct crane configuration to suit the load, site, and lift conditions.

(o) calculate or determine the net capacity for all configurations that will be used, and verify, using the load rating chart(s), that the crane has sufficient net capacity for the proposed lift.

(p) consider all factors known that might affect the crane capacity and inform the crane user of the need to make appropriate adjustments.

(q) know the standard hand signals as specified in para. 22-3.3.4 and respond to such signals from the person who is directing the lift or an appointed signalperson. When a signalperson is not required as part of the lift operation, the operator is then responsible for the movement of the crane. However, the operator shall obey a stop signal at all times, no matter who gives it.

(r) understand basic load-rigging procedures.

(s) ensure that the load and rigging weight(s) have been provided.

(t) operate the crane's functions, under normal operating conditions, in a smooth and controlled manner.

(u) stop crane operations if alerted to any unsafe condition affecting crane operations.

(v) before leaving the controls unattended:

(1) land the load under control, if practical

(2) put the controls in the "OFF" or neutral position

(w) before leaving the crane unattended:

(1) land the load under control

(2) put the controls in the "OFF" or neutral position

(3) set the transport, swing brakes, and locking devices, if equipped

(4) stop the engine or disengage power to the crane

(x) operate the crane near electric power lines only when the requirements of Section 22-3.4 and any additional requirements determined by the site supervisor have been met.

(y) refuse to operate the crane when any portion of the load or crane would enter the "prohibited zone" of energized power lines unless the site supervisor has determined that the requirements of para. 22-3.4.4 have been met.

(z) if power fails during operations

(1) land any load under control, if practical

(2) set all brakes and locking devices

(3) move all power controls to the "OFF" or neutral position

22-3.1.3.3.2 Rigger's Responsibilities. Riggers assigned to a load-handling activity shall at a minimum be responsible for (16)

(a) ensuring the weight of the load and its approximate center of gravity have been obtained, provided, or calculated

(b) selecting the proper rigging equipment, inspecting it, and complying with the applicable operating practices according to the criteria of the applicable ASME volume (i.e., B30.9, B30.10, B30.20, B30.23, and B30.26)